

Form No.  
904581

# 322

## Truck Mounted Scavenger® II Manure Spreader



### SERVICE PARTS MANUAL

GEHL®  
COMPANY

## Introduction:

When ordering service parts, specify the correct part number, full description, quantity required, the unit model number and serial number.

The model and serial numbers for this unit are stamped on a plate located on the right rear corner of the Tank. "Right" and "Left" are determined from a position standing behind the unit and facing the direction of travel. From this position, the Expeller is on the left side.

GEHL® Company reserves the right to make changes or improvements in the design or construction of any part of this unit without incurring the obligation to install such changes on any unit previously delivered.

Grease fittings and common attaching hardware, such as Cotter Pins, Set Screws, Woodruff Keys, Screws, Nuts, etc., are included in the parts lists, indented below the part it is (they are) associated with, but NOT illustrated, except where a particular routing or special fastening arrangement MUST be maintained. The hardware listed is for mounting purposes and is NOT included when the part is ordered for replacement. Refer to the abbreviations table for the various fastener descriptions. For the part number of related fasteners, refer to the Attaching Hardware Table, located on the Inside Back Cover. Standard attaching hardware torque values are also provided on the same page.

Unless otherwise specified, all Cap Screws are Grade 5, cadmium or zinc plated; Hexagon Nuts for Grade 5 Cap Screws or Bolts are Grade B; Hexagon Nuts for other Cap Screws or Bolts are Grade A.

The following abbreviations are used in this manual:

AR	- As Required
ASSY	- Assembly
ASSM	- Assembled
BRG	- Bearing
CB	- Carriage Bolt
CN	- Castellated Nut

CS	- Cap Screw (Hexagon Head)
CV	- Constant Velocity
DIA	- Diameter
EXP	- Expeller
FLN	- Flanged Lock Nut (Hexagon)
GR	- Grade
HD	- Heavy Duty
I.D.	- Inner Diameter
JN	- Jam Nut
L	- Lock (Washer)
LH	- Left Hand
LN	- Lock Nut (Hexagon)
NF	- National Fine (Thread)
NILN	- Nylon-insert Lock Nut
NPTF	- National Pipe Threaded Fitting
O.D.	- Outer Diameter
P	- Plain (Washer)
PTO	- Power Take Off
RH	- Right Hand
RHMS	- Round Head Machine Screw
RHSQNB	- Round Head Square Neck Bolt
RPM	- Revolutions Per Minute
SHSS	- Socket Head Set Screw
SHSS-SL	- Socket Head Set Screw - Self-locking (Thread)
SMV	- Slow-moving Vehicle
SN	- Slotted Nut
SQ	- Square
SQHSS	- Square Head Set Screw
T	- Tooth
THMS	- Truss-Head Machine Screw
W.A.	- Welded Assembly
W/	- With
W/O	- Without

# TABLE OF CONTENTS

Introduction . . . . .	Inside Front Cover
Table of Contents . . . . .	1
Decal Locations . . . . .	2-3
Expeller & Drives . . . . .	4-5
Expeller Gate & Liner . . . . .	6-7
Hydraulics . . . . .	8-9
Drive Shaft & Drive Guards . . . . .	10-11
Discharge Auger . . . . .	12
Hydraulic Cylinders . . . . .	13
Completing Parts . . . . .	14-17
Hydraulic System . . . . .	14-15
Mechanical Drive . . . . .	16
Fenders & Bumper . . . . .	17
Accessories . . . . .	18-21
Splash Guards . . . . .	18
Hydraulic Lid . . . . .	19
Light Kit . . . . .	20
Mud Flaps . . . . .	21
Numerical Index . . . . .	22-23
Standard Hardware Torque Specifications . . . . .	Inside Back Cover

# DECAL LOCATIONS

## GENERAL INFORMATION

Decal Locations information is provided to assist in the proper selection and application of new decals, in the event the original decal(s) become damaged or the machine is repainted. Refer to the listing for the illustration reference number, part number, description and quantity of each decal provided in the Kit. Refer to the appropriate illustration(s) for replacement location(s).

To insure proper selection of the correct replacement decals, compare all of the various closeup location photographs to your machine, before starting to refinish the unit. Then, circle each pictured decal (on or otherwise applicable to your machine) while checking off its part number in the listing. After you have verified all the decals needed for replacement, place any extra unnecessary decals aside for disposal.

## NEW DECAL APPLICATION

Surfaces **MUST** be free from dirt, dust, grease and other foreign material before applying the new Decal. To apply, remove the smaller portion of the decal backing paper and apply this part of the exposed adhesive backing to the clean surface while maintaining proper position and alignment. Peel the other portion of the backing paper off slowly while applying hand pressure to smooth out Decal surface.



## CAUTION

**ALWAYS** observe Safety Rules shown on Decals. If Decals become damaged, or if the unit is repainted, replace the Decals. If repainting, **BE SURE** that **ALL** Decals from the Kit(s) which apply to your machine, are affixed to your unit.

## PAINT NOTICE

Use this list to order paint for refinishing:

901225	One Gallon Blaze Paint
901226	One Gallon Malze Paint
610239	6 (12oz Spray Cans) Blaze Paint
610240	6 (12oz Spray Cans) Malze Paint

The Decal Set Number for the TM322 and TM329 is 098651. The Set includes the following:

Ref. No.	Part Number	Description & Quantity
1.	067493	Red Reflector Strip (2 Places)
2.	093373	CAUTION - General
3.	091442	DANGER - Rotating Auger (2 Places)
4.	093367	WARNING - General
5.	093641	DANGER - Rotating Expeller (2 Places)
6.	093365	WARNING - Rotating Component(2 Places)
7.	093366	Decal - Operator's Manual Kept Here
8.	093208	Decal - Rotating
9.	093369	WARNING - Hydraulic Oil
10.	098278	DANGER - Manure Gas

The following Decals are **NOT** included in the Decal Set but are available on an individual basis:

11.	093020	Decal - Lubrication (3 Places)
12.	081469	Decal - 322 (2 Places)
13.	081467	Decal - Scavenger II (2 Places)
14.	080491	Decal - Patent
15.	061201	Decal - GEHL (2 Places)

**NOTE:** Order PN 090910 for 71 ft roll of 2-34 in replacement Striping.

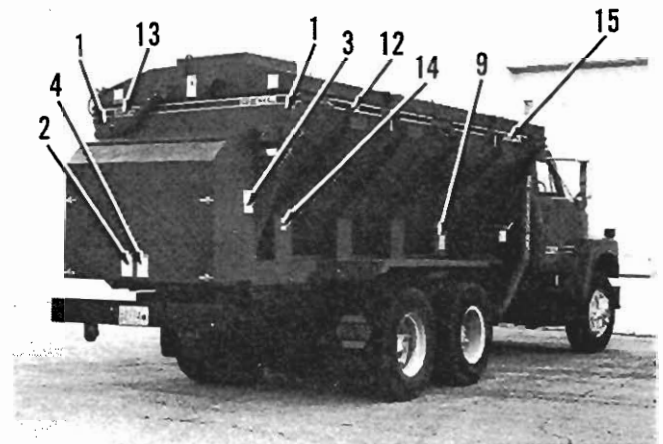

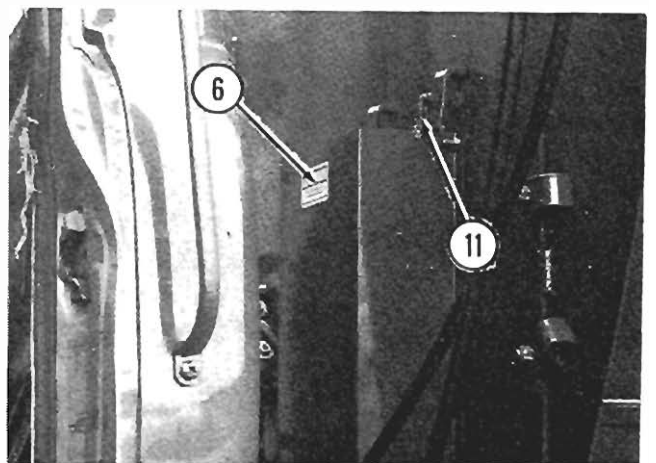
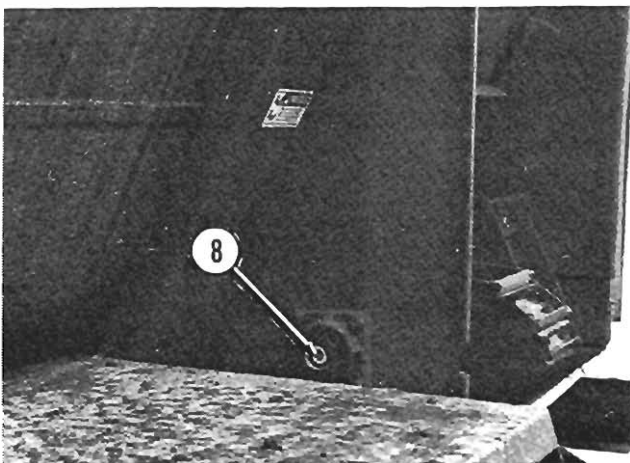
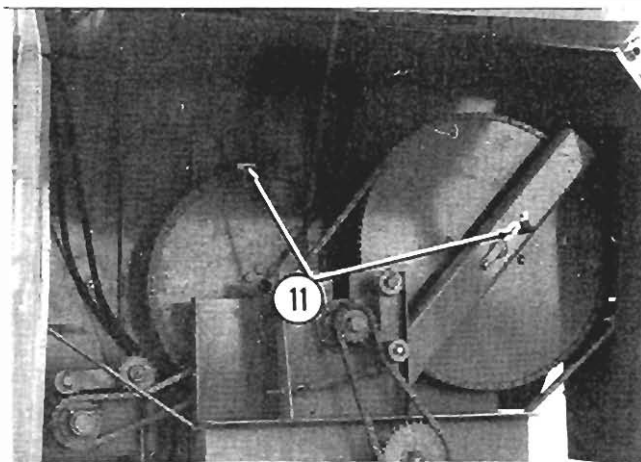
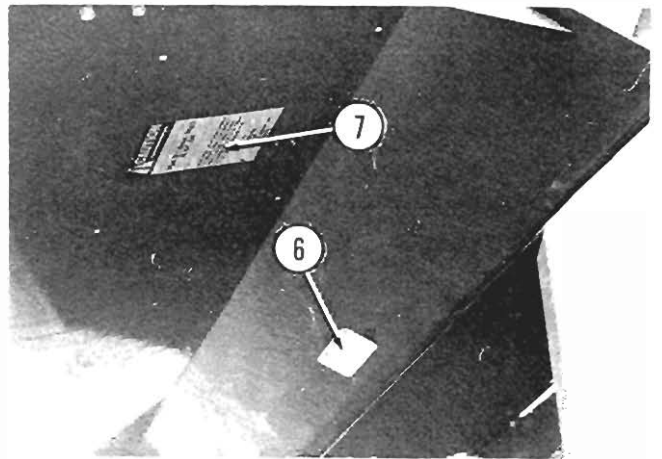
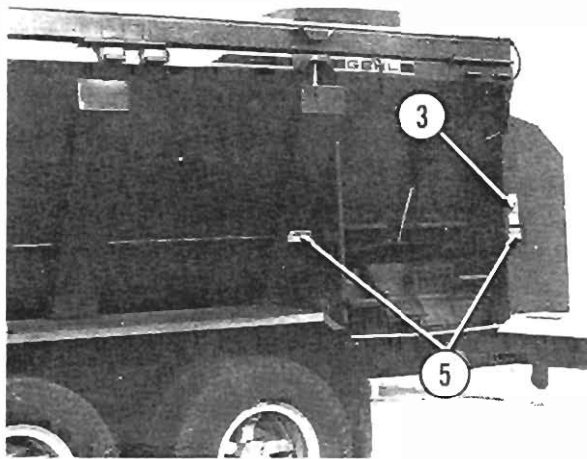

# 322 - EXPELLER & DRIVES

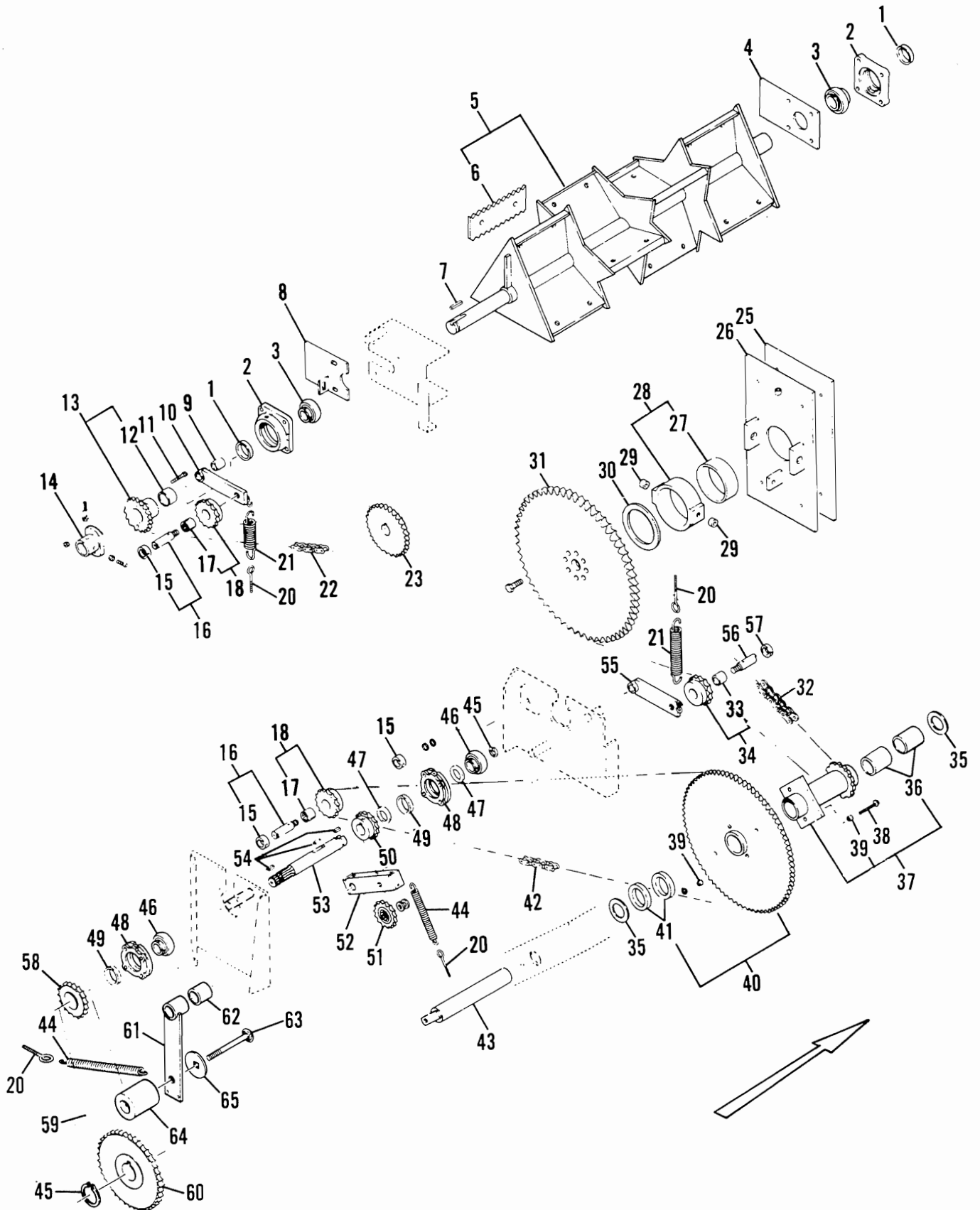

## 322 - EXPELLER & DRIVES

Ref. No.	Part No.	Part Name	Qty. Req.	Ref. No.	Part No.	Part Name	Qty. Req.
01	520195	COLLAR/BEARING .....	2	37	084795	HUB/JACKSHAFT ASSY .....	1
02	R 13216	HOUSING/BEARING .....	2		570002	FITTING/GREASE .....	1
	570002	FITTING/GREASE .....	2	38	081656 <sub>b</sub>	SHEAR BOLT 5/16X1-1/2 GR5 ...	2
	650569	CS 1/2X1-3/4 (LN,P) .....	8	39	083672	BUSHING/SHEAR .....	4
03	520194	BEARING/BALL .....	2	40	084802	SPROCKET/ASSY 119T .....	1
04	080630	PLATE/REAR .....	1	41	062815	BUSHING/BRONZE .....	2
05	081988	EXPELLER/4 POCKET ASSY .....	1	42	084801	CHAIN/ROLLER(#60)/166 LINK ...	1
06	080233	TEETH/EXPELLER REEL .....	12			(INCL (1) 500160 CONNECTOR)	
	650453	CS 1/2X1-1/2 (N,L,P) .....	24	43	083664	JACKSHAFT/ASSY .....	1
07	056230	KEY/SQUARE 3/8SQX2 .....	1		650492	CS 3/8X2-1/2 (LN) .....	1
08	083658	PLATE/EXPELLER ASSY FRT .....	1	44	080646	SPRING/EXTENSION .....	2
	650495	CS 1/2X1-1/4 (N,L) .....	2	45	051904	RING/RETAINING .....	4
09	084603	PIVOT/IDLER .....	1	46	083666	BEARING/BALL .....	2
10	080616	IDLER ARM ASSY .....	1	47	H 7119	SPACER/BEARING .....	AR
	655020	PIN/COTTER 3/16X1-1/2 (P 1") ..	2	48	083667	HOUSING/BEARING .....	2
11	077066 <sub>a</sub>	CS 1/4X1-1/2 (LN) .....	2		570008	FITTING/GREASE .....	2
12	045171	BUSHING/BRONZE .....	1		650569	CS 1/2X1-3/4 (LN) .....	8
13	084601	SPROCKET/ASSY 20T .....	1	49	076082	COLLAR/LOCK .....	2
14	083669	FLANGE/SHEAR ASSY .....	1	50	087052	SPROCKET 13T .....	1
	650226	SQHSS 3/8X1 (JN) .....	2		650201	SHSS 5/16X5/16 .....	2
15	S 16174	COLLAR/SET .....	3	51	056845	SPROCKET/IDLER ASSY .....	1
	650201	SHSS 5/16X5/16 .....	3		650647	CS 5/8X2 (L,3P) .....	1
16	080617	SHAFT/IDLER .....	2	52	080618	ARM/IDLER ASSY .....	1
17	520147	BEARING/NEEDLE .....	2		655020	PIN/COTTER 3/16X1-1/2 (P 1") ..	1
18	080654	SPROCKET/IDLER ASSY 17T ...	2	53	110469	SHAFT/PTO .....	1
20	066172	EYEBOLT (LN,P 5/16) .....	4	54	C 14036	KEY/TRANSMISSION .....	3
21	080645	SPRING/EXTENSION .....	2	55	080614	ARM/IDLER ASSY .....	1
22	084798	CHAIN/ROLLER #60/88 LINK ...	1		655020	PIN/COTTER 3/16X1-1/2 (P 1") ..	1
		(INCL (1) 500160 CONNECTOR)		56	080615	SHAFT/IDLER (INCL 57) .....	1
23	084799	SPROCKET/EXP DR #60X16T ...	1	57	081501	COLLAR/SET .....	1
	650201	SHSS 5/16X5/16 (JN) .....	2		650201	SHSS 5/16X5/16 .....	1
25	090509	LINER/AUGER FRONT .....	1	58	080655	SPROCKET/15T .....	1
26	090505	PLATE/AUGER SLIDE FT .....	1		650201	SHSS 5/16X5/16 .....	2
	570005	FITTING/GREASE .....	4	59	043737	CHAIN/ROLLER .....	1
27	083654	BEARING/AUGER FIBER .....	1	60	080656	SPROCKET/30T .....	1
28	090585	TRUNNION ASSY .....	1		650201	SHSS 5/16X5/16 .....	1
29	H 7710	BUSHING/BRONZE .....	2	61	110017	IDLER/ASSY .....	1
	650844	CS 5/8X1-3/4 (P) .....	2		655020	PIN/COTTER 3/16X1-1/2 (P 1") ..	1
30	083663	SPACER .....	3	62	110020	SPACER .....	1
31	080394	SPROCKET/ASSY #100X60T ...	1	63	652064	CB 3/8X4 (N,L) .....	1
	651075	CS 5/8X1-3/4 GR.8 (L) .....	8	64	090558	TIGHTENER/CHAIN .....	1
32	084797	CHAIN/ROLLER (#100) .....	1	65	090327	WASHER .....	1
33	081500	BUSHING/BRONZE .....	1				
34	081498	SPROCKET/IDLER (100X12) ...	1	a)	For replacement Shear Bolts, order 900084 containing 8 Bolts & LN.		
35	076085	BUSHING/MACHINERY .....	AR	b)	For replacement Shear Bolt, order 081655 containing 8 Bolts & LN.		
36	083678	BUSHING/BRONZE .....	2				

# 322 - EXPELLER GATE & LINER

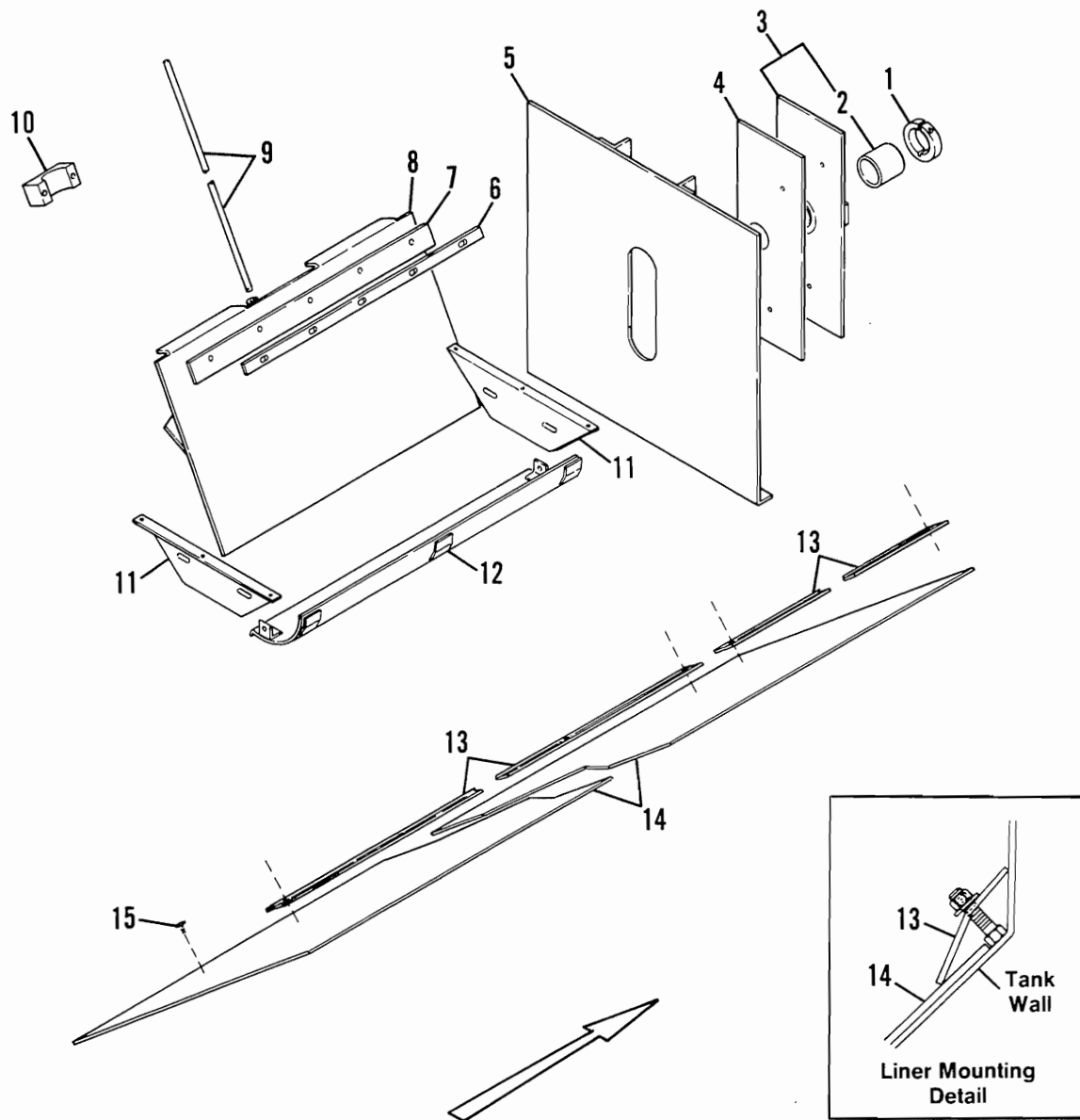

## 322 - EXPELLER GATE & LINER

Ref. No.	Part No.	Part Name	Qty. Req.	Ref. No.	Part No.	Part Name	Qty. Req.
01	088749	COLLAR/LOCK .....	1		655048	PIN/COTTER 5/32X1-1/4 .....	1
	650201	SHSS 5/16X5/16 .....	2	10	080675	BLOCK/CYLINDER CLAMP .....	1
02	090501	BUSHING/BRONZE.....	1		650379	CS 1/2X3 (L) .....	2
03	090499	SLIDE/REAR AUGER ASSY .....	1	11	083681	PAN/SIDE .....	2
	570002	FITTING/GREASE .....	2		650487	CS 5/16X1 (N,L) .....	6
04	090502	LINER/AUGER REAR .....	1	12	082016	PAN/EXPELLER REEL .....	1
05	097853	PLATE/AUGER ASSY REAR .....	1		650545	CS 5/16X1-1/4 (LN) .....	2
06	082011	WIPER/RETAINER (5LN,5P 3/8) ..	1	13	080674	HOLDDOWN/LINER (14FLN 3/8) ..	2
07	082010	WIPER/RUBBER .....	1	14	081742	LINER/POLYMER 60X191 .....	1
08	081993	GATE ASSY .....	1	15	651069	BOLT/FLAT HD (N,L) .....	8
09	082271	ROD/GATE INDICATOR .....	1				

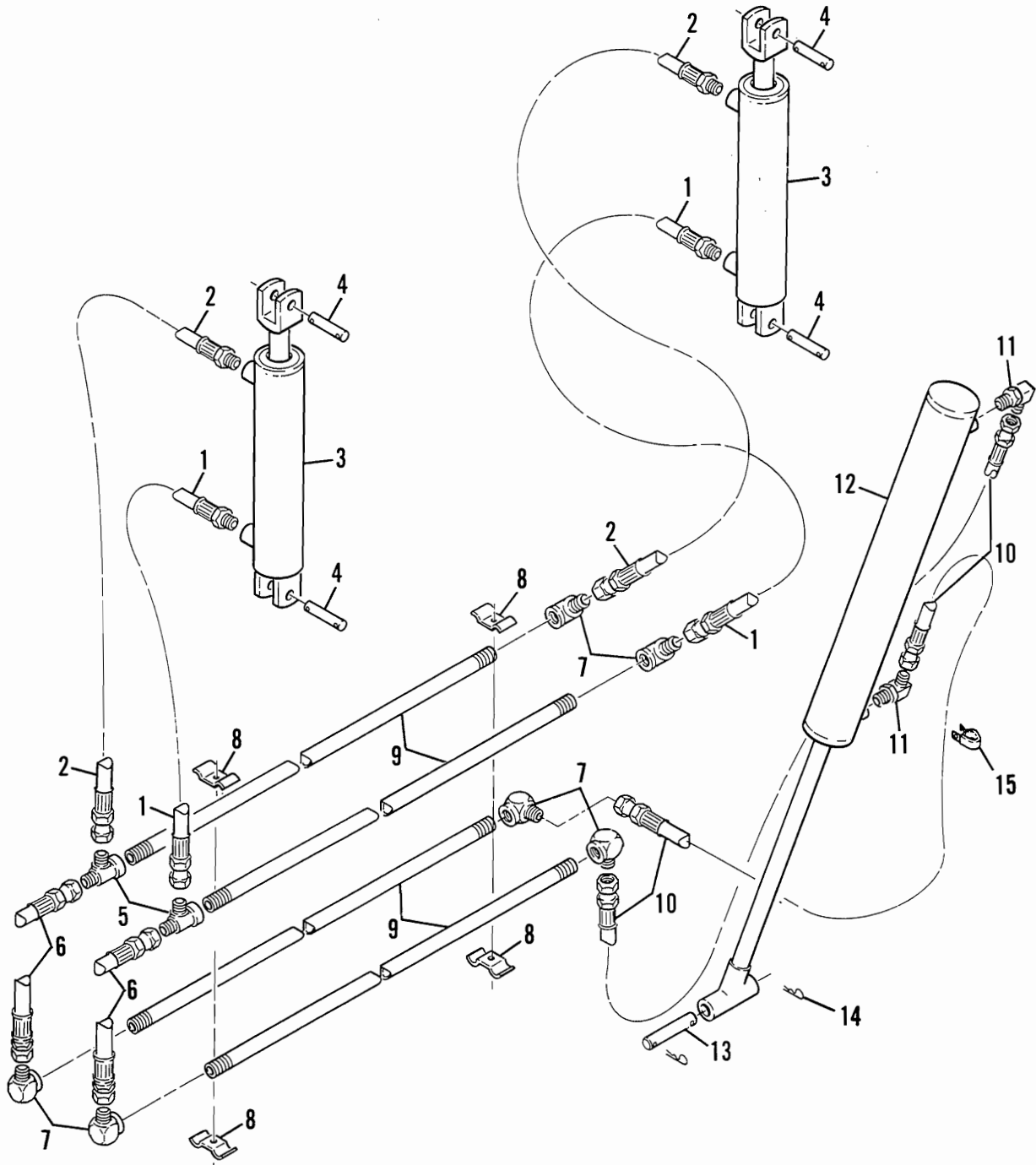

## 322 - HYDRAULICS

Ref. No.	Part No.	Part Name	Qty. Req.	Ref. No.	Part No.	Part Name	Qty. Req.
01	110037	HOSE/ASSY 3/8X20 .....	2	09	110051	TUBE/HYDRAULIC .....	4
02	110038	HOSE/ASSY 3/8X22 .....	2	10	097478	HOSE/ASSY 126" .....	2
03	110450 <sub>a</sub>	CYLINDER/HYD 2X8 .....	2	11	068938	ELBOW/90 DEG ADJUSTABLE ...	2
04	076513	PIN/CLEVIS .....	4	12	110035 <sub>a</sub>	CYLINDER/HYDRAULIC 2X16 ...	1
	650878	PIN/COTTER 5/32X1 .....	4	13	080629	PIN/GATE CYLINDER .....	1
05	097307	TEE .....	2	14	076099	COTTER/HAIR PIN .....	2
06	097795	HOSE/ASSY .....	4	15	067880	CLAMP/HOSE (LN 3/8) .....	6
07	110448	ELBOW/90 DEG FEMALE .....	6	a) For components, see page titled Hydraulic Cylinders			
08	18453	CLAMP/HOSE .....	8				
	650528	CS 3/8X2 (LN,P) .....	4				

# 322 - DRIVE SHAFT & DRIVE GUARDS

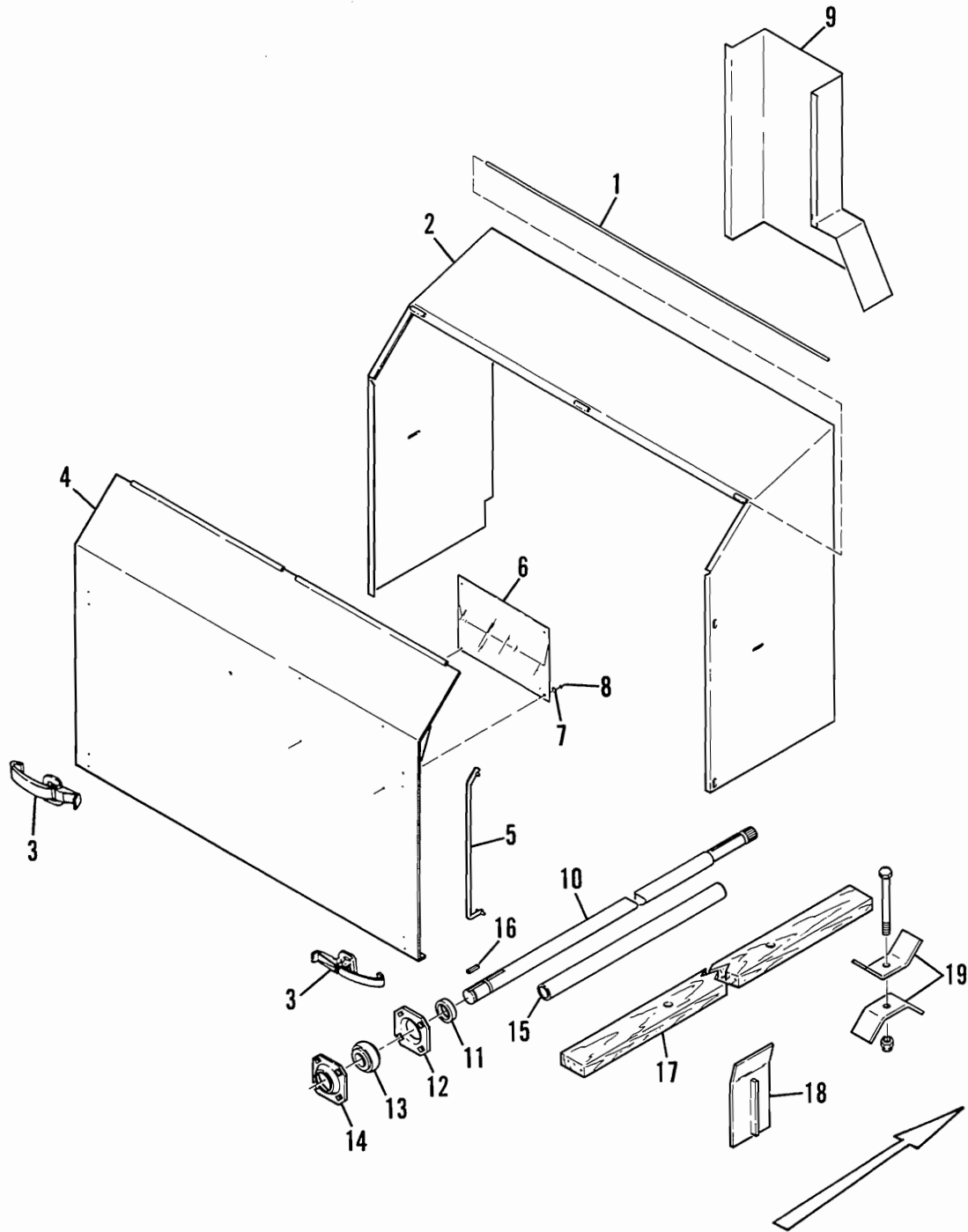

## 322 - DRIVE SHAFT & DRIVE GUARDS

Ref. No.	Part No.	Part Name	Qty. Req.	Ref. No.	Part No.	Part Name	Qty. Req.
01	110446	PIN/GUARD HINGE .....	1	11	076082	COLLAR/LOCK .....	4
	655006	PIN/COTTER 1/8X1 .....	2	12	110022	FLANGETTE/RELUBE 80MM .....	4
02	110438	SHIELD/ASSY .....	1		650811	CB 1/2X1 (N,L) .....	16
	650487	CS 5/16X1 (N,L) .....	12	13	083666	BEARING/BALL .....	4
03	054586	LATCH .....	4	14	110023	FLANGETTE/RELUBE 80MM .....	4
	650943	THMS 1/4X1/2 (N,L) .....	8		053894	FITTING/GREASE .....	4
04	110443	COVER/SHIELD ASSY .....	1	15	097797	SHIELD/SHAFT FRONT 30" .....	1
05	078580	POUCH/MANUAL .....	1		097798	SHIELD/SHAFT CENTER 118-1/2" .....	1
06	097688	ROD/GUARD SUPPORT .....	1		097799	SHIELD/SHAFT REAR 54-3/4" .....	1
	057864	PIN/SPRING .....	2	16	C 14036	KEY/TRANSMISSION .....	1
07	068642	WASHER .....	4	17	097493	RAIL/FRAME .....	2
08	079923	RIVET/BLIND .....	4		652058	CB 3/8X3 (N,L) .....	8
09	097702	SHIELD ASSY/REAR(4LN,4P 3/8) .....	1	18	092803	BRACKET/HOLD-DOWN .....	8
10	110447	SHAFT/DRIVE .....	1		650526	CS 3/4X6 (NILN) .....	4
				19	097699	STOP/ASSY .....	2

# 322 - DISCHARGE AUGER

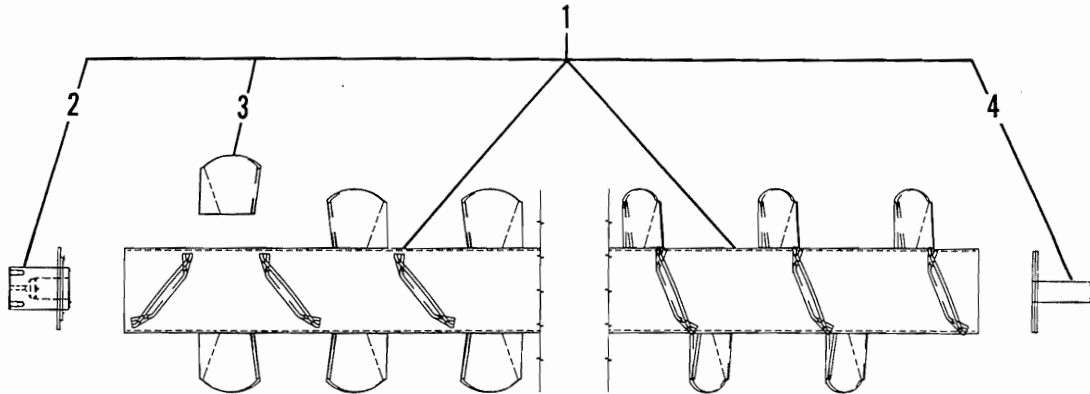

Ref. No.	Part No.	Part Name	Qty. Req.	Ref. No.	Part No.	Part Name	Qty. Req.
01	110050	AUGER/ASSEMBLY .....	1	03	080290	FLIGHT/FORMED .....	47
02	083647	SHAFT/FRONT ASSY.(WELD) ....	1	04	110061	SHAFT/REAR ASSY (WELD) .....	1

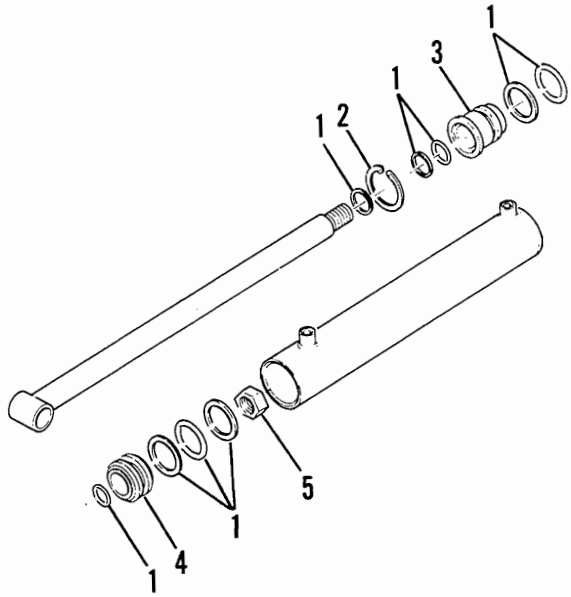

Ref. No.	Part No.	Part Name	Qty. Req.
	110035	CYLINDER/HYD 2X16 .....	1
		CONSISTS OF:	
01	089693	KIT/REPAIR .....	1
02	089689	SNAP RING .....	1
03	089691	HEAD .....	1
04	089690	PISTON .....	1
05	089692	NUT .....	1

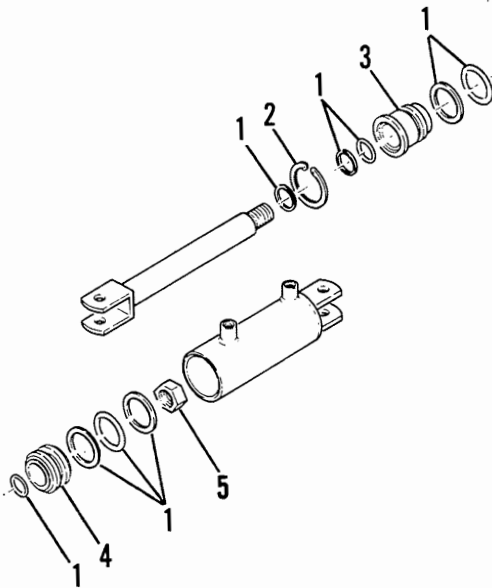

Ref. No.	Part No.	Part Name	Qty. Req.
	110450	CYLINDER/HYD 2 X 8 .....	2
		CONSISTS OF:	
01	089686	KIT/REPAIR .....	1
02	089683	SNAP RING .....	1
03	089685	HEAD .....	1
04	089684	PISTON .....	1
05	089679	NUT .....	1



## 322 - COMPLETING PARTS

Ref. No.	Part No.	Part Name	Qty. Req.	Ref. No.	Part No.	Part Name	Qty. Req.
01	110374	VALVE/CONTROL ASSY .....	1	26	097785	HOSE/ASSY .....	1
	650487	CS 5/16X1 (N,L) .....	4	27	068105	ELBOW/90 DEG 7/8X3/4 .....	1
02	077969	UNION/90 DEG .....	8	28	064654	FILTER/OIL .....	1
03	660003	PLUG/PIPE 3/8 .....	2		650448	CS 1/4X3/4 (L) .....	2
04	097926 <sub>b</sub>	PUMP/GEAR ASSY .....	1	29	064655	MALE/CONNECTOR .....	1
	650528	CS 3/8X2 (N,L) .....	2	30	064656	TUBE/FILTER TO RESERVOIR ...	1
05	097297	PLATE/PUMP MOUNTING .....	1	31	097795	HOSE/ASSY .....	4
06	110017	IDLER/EXPELLER DRIVE ASSY ..	1	32	097796 <sub>a</sub>	HOSE/ASSY .....	2
	654016	WASHER/PLAIN 1 .....	1	33	097856	COVER/CONTROL VALVE .....	1
	655020	PIN/COTTER 3/16X1-1/2 .....	1	34	098298	BRACKET/FILTER (329) .....	1
07	064462	SUPPORT/RESERVOIR .....	1		098276	BRACKET/FILTER (322) .....	1
	650487	CS 5/16X1 (N,L,P) .....	4		650487	CS 5/16X1 (N,L) .....	1
08	097782	SUPPORT/RESERVOIR .....	2	35	097807	BOX/CONTROL ASSY (INCL 36) ..	1
	650487	CS 5/16X1 (N,L) .....	4	36	097848	HARNES/VALVE .....	1
09	076841	RESERVOIR .....	1	37	064834	SHEAVE/PUMP .....	1
10	064651	STRAP/RESERVOIR (N,L 5/16) ..	2		650198	SHSS 1/4X3/8 .....	2
11	070060	HOSE/OUTLET 8 FOOT .....	1	38	065031	SHEAVE/PUMP DRIVE .....	1
12	055335	CLAMP/HOSE .....	3		655533	KEY/WOODRUFF HARD 5/16X1 ..	1
13	097783	TUBE/SUCTION .....	1		650198	SHSS 1/4X3/8 .....	2
14	064644	CONNECTOR/MALE .....	1		650487	CS 5/16X1 (L) .....	1
15	066841	UNION/SWIVEL ADAPTER .....	1	39	054407	WASHER .....	1
16	062910	NIPPLE/SWIVEL ADAPTER .....	1	40	092538	BELT/POWERBAND .....	1
17	058654	ELBOW/STREET 90 DEG .....	1	41	081140	IDLER/PULLEY .....	1
18	058655	TEE/STEEL HYD PIPE .....	1		650631	CS 5/8X4 (NILN,AR-P) .....	1
19	097784	HOSE/ASSY .....	2	42	B 11108	SPRING/EXTENSION .....	1
20	057655	REDUCER/STEEL PIPE .....	1	43	066172	EYEBOLT 5/16 (N) .....	1
21	075877	VALVE/IN LINE RELIEF .....	1	44	110665	CHANNEL/MOUNTING .....	1
22	042618	UNION/90 DEG ADAPTER .....	1	45	064650	CAP/RESERVOIR .....	1
23	580060	UNION/90 DEG ADAPTER .....	1				
24	048952	UNION/TEE ADAPTER .....	1				
25	073212	NIPPLE/MALE PIPE .....	1				

a) Not Illustrated. Hoses to Optional Hydraulic Lid

b) For replacement Seal Kit order 088449

# 322 - COMPLETING PARTS

## 804846 Mechanical Drive Parts Kit

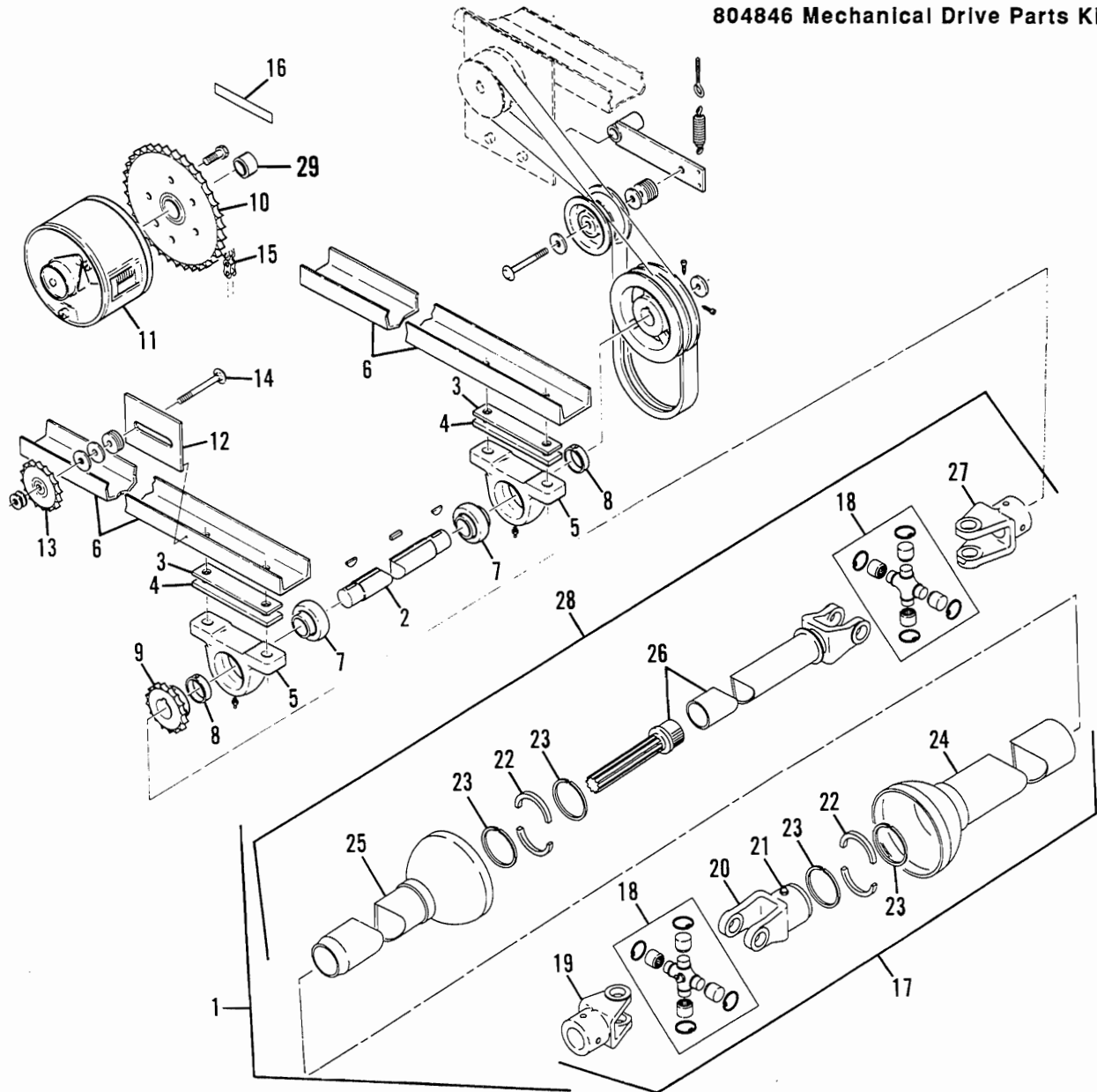

Ref. No.	Part No.	Part Name	No. Req.	Ref. No.	Part No.	Part Name	Qty. Req.
01	097741	SHAFT/DRIVE ASSY	1	12	097584	BRACKET/IDLER	1
	650201	SHSS 5/16X5/16	4	13	056845	SPROCKET/IDLER ASSY	1
02	110591	JACKSHAFT	1	14	650843	CB 5/8X4 (4P,L,N)	1
	655537	KEY/WDRF HD 5/16X1-1/4	2	15	080659	#60 ROLLER CHAIN 92 PITCH	1
	C 14036	KEY/SQ 3/8X1-1/4	1	16	098105	DECAL/ENGINE RPM	1
03	097530	SPACER/1/4	4	17	115778	JOINT/ASSY FEMALE W/GUARD	1
04	097531	SPACER/3/8	4	18	510114	KIT/CENTER CROSS	2
05	M 12215	HOUSING/BEARING	2	19	115776	YOKE	1
	570002	FITTING/GREASE	2	20	115777	YOKE	1
	650647	CS 5/8X2 (N,L,P)	4	21	570002	FITTING/GREASE	2
06	110665	CHANNEL/JACKSHAFT MTG	2	22	510023	BEARING/NYLON	2
07	083666	BEARING/BALL	2	23	510100	RETAINER/BEARING	4
08	076082	COLLAR/LOCK	2	24	115779	GUARD/OUTER	1
09	080655	SPROCKET/15T	1	25	115781	GUARD/INNER	1
	650201	SHSS 5/16X5/16	2	26	115782	YOKE/TUBE & STUB PLUG	1
10	097764	SPROCKET/40T (INCL 29)	1	27	115784	YOKE	1
	655017	CS M12X35	6	28	115783	JOINT/ASSY MALE W/GUARD	1
11	110373	CLUTCH/ASSD	1	29	045-18274	BUSHING	1

804848 Fender & Bumper Parts Kit

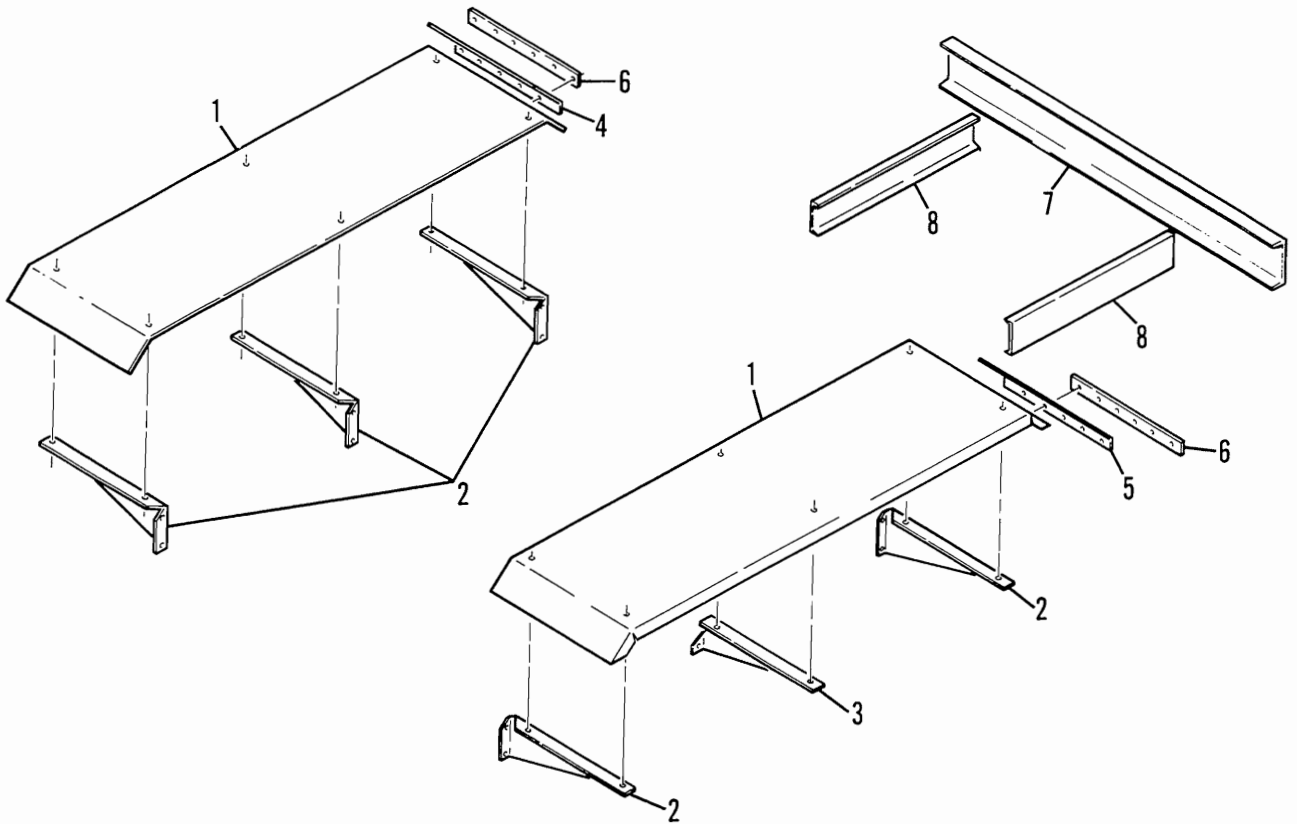

Ref. No.	Part No.	Part Name	Qty. Req.	Ref. No.	Part No.	Part Name	Qty. Req.
01	097494	FENDER .....	2	05	097752	EXTENSION/FLAP LT .....	1
02	097511	BRACE/FENDER .....	5		650486	CS 5/16X3/4 (N,L) .....	4
	650486	CS 5/16X3/4 (N,L) .....	20	06	097681	STRAP/FLAP .....	2
03	097730	BRACE/FENDER .....	1		650486	CS 5/16X3/4 (N,L) .....	12
	650486	CS 5/16X3/4 (N,L) .....	3	07	097635	CHANNEL/BUMPER .....	1
04	097682	EXTENSION/FLAP RT .....	1	08	097932	MOUNT/BUMPER .....	2
	650486	CS 5/16X3/4 (N,L) .....	4				

803469 Splash Guards

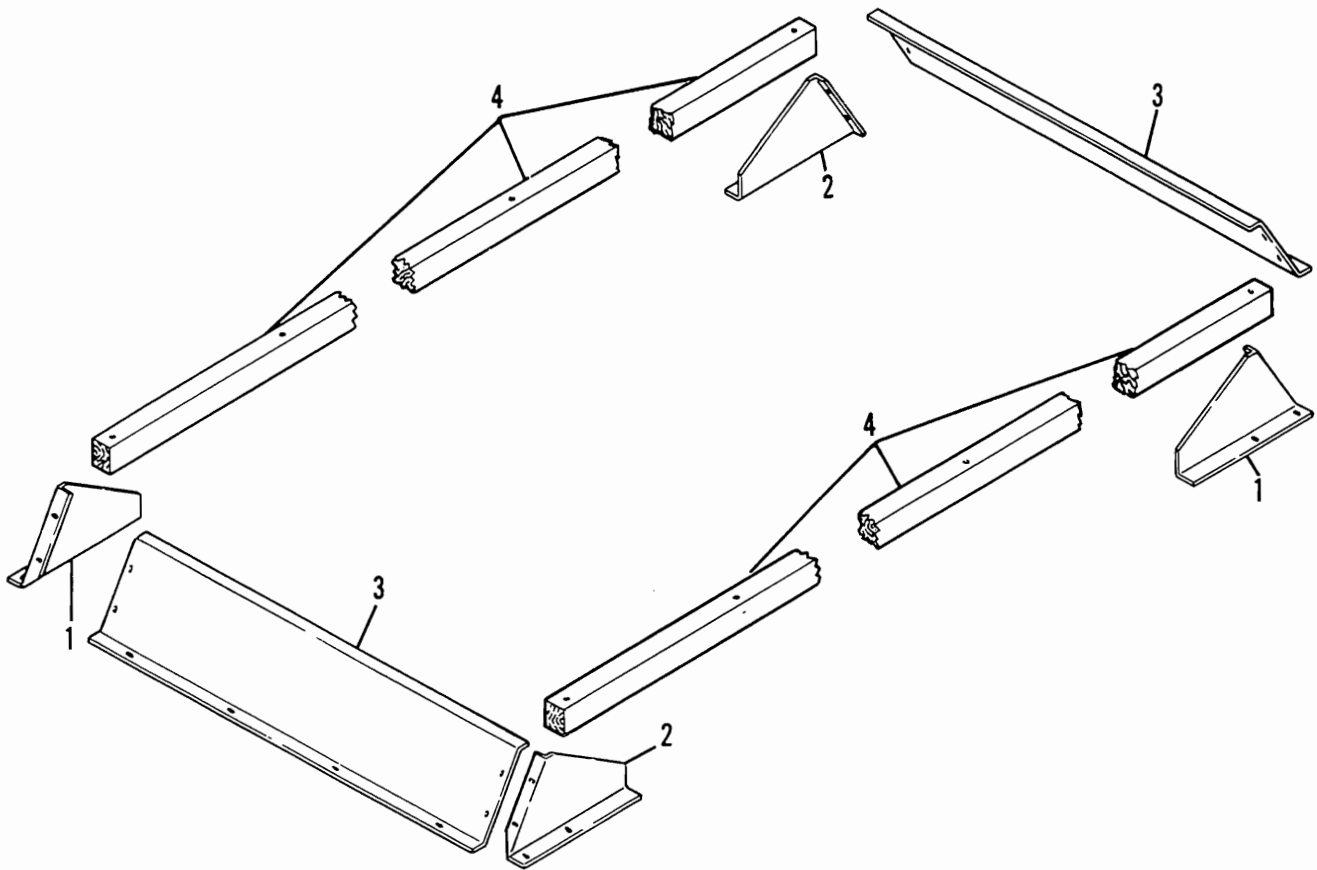

Ref. No.	Part No.	Part Name	Qty. Req.	Ref. No.	Part No.	Part Name	Qty. Req.
	803469	GUARD/SPLASH W/SIDE RAILS	. 1	03	081748	SHIELD	.....2
		CONSISTS OF:			650490	CS 3/8X1 (N,L,P)	.....8
01	080110	SHIELD/SPLASH RT FRT	..... 2	04	080882	RAIL 2-1/2SQ X 174	.....2
	650490	CS 3/8X1 (N,L,16P)	..... 8		650540	CB 3/8X3-1/2 (N,L)	.....8
02	080111	SHIELD/SPLASH LT FRT	..... 2				
	650490	CS 3/8X1 (N,L,16P)	..... 8				

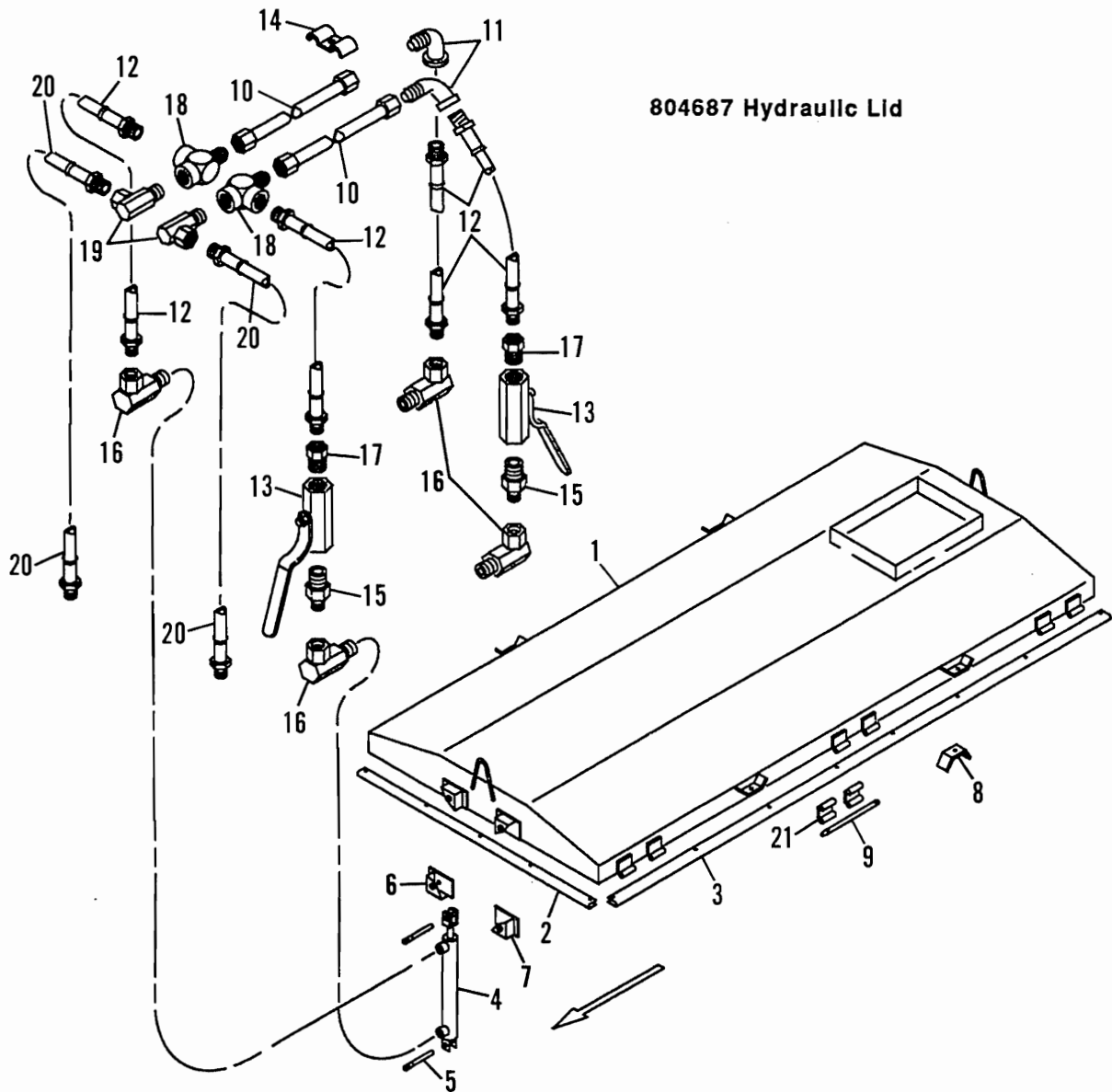

804687 Hydraulic Lid

Ref. No.	Part No.	Part Name	Qty. Req.	Ref. No.	Part No.	Part Name	Qty. Req.
01	092587	LID/TANK ASSY .....	1	10	092805	TUBE/HYDRAULIC .....	2
02	092808	SEAL/LID END .....	2	11	064673	ELBOW/FEMALE .....	2
	651069	EB 5/16X1-1/4 (N,L) .....	14	12	083231	HOSE/ASSY .....	4
03	092809	SEAL/LID SIDE .....	2	13	092813	VALVE .....	2
	651069	EB 5/16X1-1/4 (N,L) .....	32	14	018453	CLAMP/HOSE .....	3
04	606086	CYLINDER/HYD 2 X 18 .....	2		070856	NUT/FLANGE LOCK 3/8 .....	3
05	092812	PIN/CYLINDER PIVOT .....	4	15	072901	NIPPLE .....	2
	074090	PIN/SPRING .....	4	16	042618	UNION/90 DEG SWIVEL ADAPT ..	4
06	092593	BRACKET/CYL PIVOT ASSY LT ..	2	17	057655	REDUCER/STEEL PIPE .....	2
07	092804	BRACKET/CYL PIVOT ASSY R ...	2	18	092806	FITTING/HYDRAULIC .....	2
08	092803	BRACKET/HOLD DOWN .....	4	19	580052	ELBOW/90 DEG SWIVEL ADAPT ..	2
	650526	CS 3/4X6 (NILN) .....	4	20	083250	HOSE/ASSY .....	2
09	092810	PIN/HINGE .....	6	21	092814	HINGE/LID LOWER ASSY .....	12
	655024	PIN/COTTER 3/16X2 .....	12				
	092811	PIN/DRIVE .....	1				
	655016	PIN/COTTER 3/16X1 .....	2				

804578 Light Kit

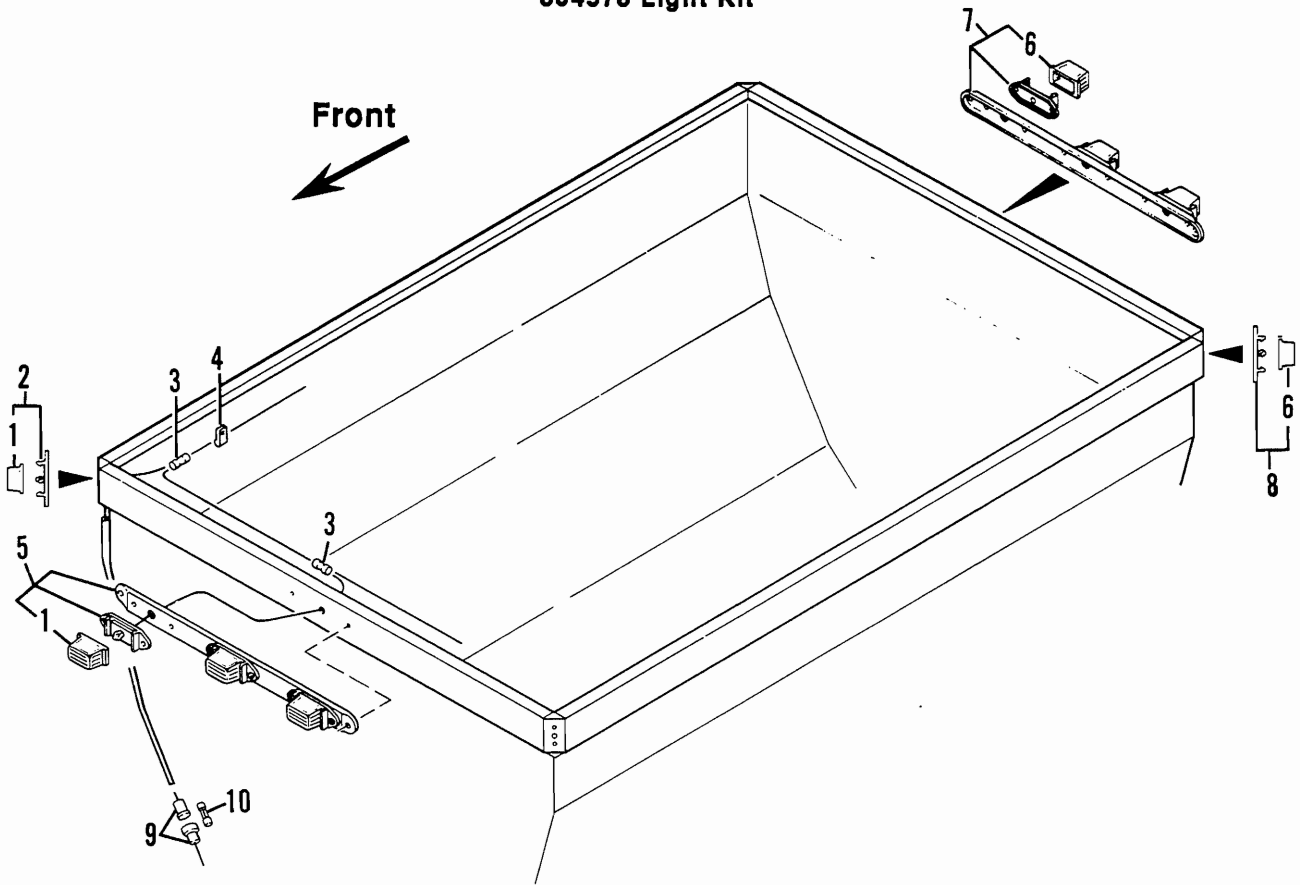

Ref. No.	Part No.	Part Name	Qty. Req.	Ref. No.	Part No.	Part Name	Qty. Req.
	804578 <sub>a</sub>	LIGHT KIT .....	1	06	110422	LENS/MINI-LITE - RED .....	3
		CONSISTS OF :		07	110413	IDENTIFICATION BAR - RED .....	1
01	110423	LENS/MINI-LITE - AMBER .....	5		650702	STS #6-32X3/8 .....	2
02	110415	MINI-LITE - AMBER .....	2	08	110414	MINI-LITE - RED .....	2
	650702	STS #6-32X3/8 .....	4		650702	STS #6-32X3/8 .....	4
03	071105	BUTT CONNECTOR! .....	AR	09	110219	INLINE FUSE HOLDER .....	1
04	110416	CLIP .....	AR	10	076056	FUSE/10 AMP .....	1
05	110412	IDENTIFICATION BAR - AMBER .	1				
	650702	STS #6-32X3/8 .....	2				
				a)		100 feet of 16 AWG Wire is included	

804580 Mud Flaps Kit

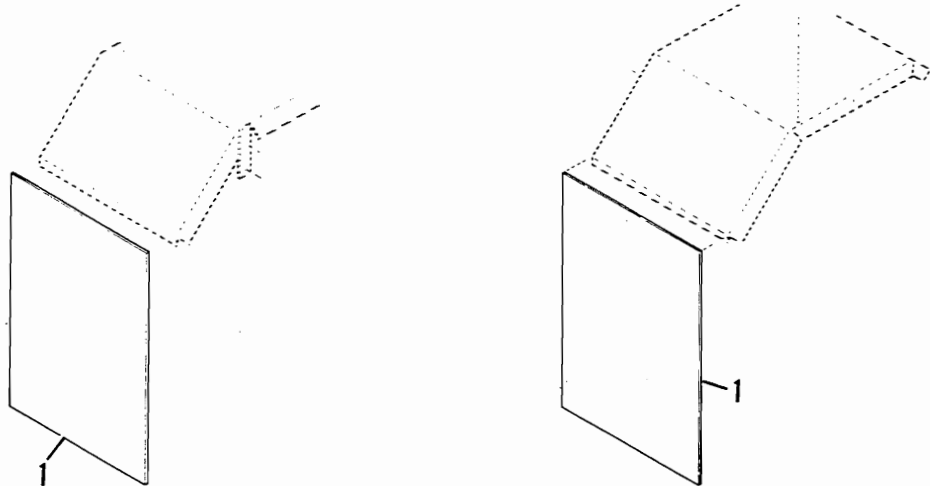

Ref. No.	Part No.	Part Name	Qty. Req.	Ref. No.	Part No.	Part Name	Qty. Req.
804580		MUD FLAPS .....	1	01	110421	MUD FLAP .....	2
		CONSISTS OF:			650533	CS 3/8X1-1/2 (N,L,P) .....	12

# NUMERICAL INDEX



Part No.	Page No.	Ref. No.	Part No.	Page No.	Ref. No.	Part No.	Page No.	Ref. No.	Part No.	Page No.	Ref. No.
B 11108	15	42	070856	19		082016	07	12	092805	19	10
C 14036	05	54	071105	20	03	082271	07	09	092806	19	18
C 14036	11	16	072901	19	15	083231	19	12	092808	19	02
H 7119	05	47	073212	15	25	083250	19	20	092809	19	03
H 7710	05	29	074090	19		083647	12	02	092810	19	09
M 12215	16	05	075877	15	21	083654	05	27	092811	19	
R 13216	05	02	076056	20	10	083658	05	08	092812	19	05
S 16174	05	15	076082	05	49	083663	05	30	092813	19	13
<b>010000</b>			076082	11	11	083664	05	43	092814	19	21
018453	09	08	076082	16	08	083666	05	46	093509	16	13
018453	19	14	076085	05	35	083666	11	13	097297	15	05
<b>040000</b>			076099	09	14	083666	16	07	097307	09	05
042618	15	22	076513	09	04	083667	05	48	097478	09	10
042618	19	16	076841	15	09	083669	05	14	097493	11	17
043737	05	59	077066	05	11	083672	05	39	097494	17	01
045171	05	12	077969	15	02	083678	05	36	097511	17	02
048952	15	24	078580	11	05	083681	07	11	097530	16	03
<b>050000</b>			079923	11	08	084601	05	13	097531	16	04
051904	05	45	<b>080000</b>			084603	05	09	097584	16	12
053894	11		080110	18	01	084795	05	37	097635	17	07
054407	15	39	080111	18	02	084797	05	32	097681	17	06
054586	11	03	080233	05	06	084798	05	22	097682	17	04
055335	15	12	080290	12	03	084799	05	23	097688	11	06
056230	05	07	080394	05	31	084801	05	42	097699	11	19
056845	05	51	080614	05	55	084802	05	40	097702	11	09
057655	15	20	080615	05	56	087052	05	50	097730	17	03
057655	19	17	080616	05	10	088749	07	01	097741	16	01
057864	11		080617	05	16	089679	13	05	097752	17	05
058654	15	17	080618	05	52	089683	13	02	097764	16	10
058655	15	18	080629	09	13	089684	13	04	097782	15	08
<b>060000</b>			080630	05	04	089685	13	03	097783	15	13
062815	05	41	080645	05	21	089686	13	01	097784	15	19
062910	15	16	080646	05	44	089689	13	02	097785	15	26
064462	15	07	080654	05	18	089690	13	04	097795	09	06
064644	15	14	080655	05	58	089691	13	03	097795	15	31
064650	15	45	080655	16	09	089692	13	05	097796	15	32
064651	15	10	080656	05	60	089693	13	01	097797	11	15
064654	15	28	080659	16	15	<b>090000</b>			097798	11	
064655	15	29	080674	07	13	090327	05	65	097799	11	
064656	15	30	080675	07	10	090499	07	03	097807	15	35
064673	19	11	080882	18	04	090501	07	02	097848	15	36
064834	15	37	081140	15	41	090502	07	04	097853	07	05
065031	15	38	081498	05	34	090505	05	26	097856	15	33
066172	05	20	081500	05	33	090509	05	25	097926	15	04
066172	15	43	081501	05	57	090558	05	64	097932	17	08
066841	15	15	081656	05	38	090585	05	28	098105	16	16
067880	09	15	081742	07	14	092538	15	40	098276	15	
068105	15	27	081748	18	03	092587	19	01	098298	15	34
068642	11	07	081988	05	05	092593	19	06	<b>100000</b>		
068938	09	11	081993	07	08	092803	11	18	110017	05	61
<b>070000</b>			082010	07	07	092803	19	08	110017	15	06
070060	15	11	082011	07	06	092804	19	07	110020	05	62

# NUMERICAL INDEX

Part No.	Page No.	Ref. No.	Part No.	Page No.	Ref. No.	Part No.	Page No.	Ref. No.	Part No.	Page No.	Ref. No.
110022	11	12	651069	07	15						
110023	11	14	652064	05	63						
110035	09	12	660003	15	03						
110035	13		<b>800000</b>								
110037	09	01	803469	18							
110038	09	02	804578	20							
110050	12	01	804580	21							
110051	09	09	<b>045-00000</b>								
110061	12	04	045-18274	16	29						
110219	20	09									
110373	16	11									
110374	15	01									
110412	20	05									
110413	20	07									
110414	20	08									
110415	20	02									
110416	20	04									
110421	21	01									
110422	20	06									
110423	20	01									
110438	11	02									
110443	11	04									
110446	11	01									
110447	11	10									
110448	09	07									
110450	09	03									
110450	13										
110469	05	53									
110591	16	02									
110665	15	44									
110665	16	06									
115776	16	19									
115777	16	20									
115778	16	17									
115779	16	24									
115781	16	25									
115782	16	26									
115783	16	28									
115784	16	27									
			<b>500000</b>								
510023	16	22									
510100	16	23									
510114	16	18									
520147	05	17									
520194	05	03									
520195	05	01									
570002	16	21									
580052	19	19									
580060	15	23									
			<b>600000</b>								
606086	19	04									
650843	16	14									

## Notes

## TORQUE SPECIFICATIONS FOR STANDARD MACHINE HARDWARE

SIZE	SAE GRADE #2 		SAE GRADE #5 		SAE GRADE #8 	
	DRY	LUB.	DRY	LUB.	DRY	LUB.
8 - 32	19 In. Lbs.	14 In. Lbs.	30 In. Lbs.	22 In. Lbs.	41 In. Lbs.	31 In. Lbs.
8 - 36	20 "	15 "	31 "	23 "	43 "	32 "
10 - 24	27 "	21 "	43 "	32 "	60 "	45 "
10 - 32	31 "	23 "	49 "	36 "	68 "	51 "
1/4 - 20	66 "	50 "	9 Ft. Lbs.	75 "	12 Ft. Lbs.	9 Ft. Lbs.
1/4 - 28	76 "	56 "	10 "	86 "	14 "	10 "
5/16 - 18	11 Ft. Lbs.	9 Ft. Lbs.	17 "	13 Ft. Lbs.	25 "	18 "
5/16 - 24	12 "	9 "	19 "	14 "	25 "	20 "
3/8 - 16	20 "	15 "	30 "	23 "	45 "	35 "
3/8 - 24	23 "	17 "	35 "	25 "	50 "	35 "
7/16 - 14	32 "	24 "	50 "	35 "	70 "	55 "
7/16 - 20	36 "	27 "	55 "	40 "	80 "	60 "
1/2 - 13	50 "	35 "	75 "	55 "	110 "	80 "
1/2 - 20	55 "	40 "	90 "	65 "	120 "	90 "
9/16 - 12	70 "	55 "	110 "	80 "	150 "	110 "
9/16 - 18	80 "	60 "	120 "	90 "	170 "	130 "
5/8 - 11	100 "	75 "	150 "	110 "	220 "	170 "
5/8 - 18	110 "	85 "	180 "	130 "	240 "	180 "
3/4 - 10	175 "	130 "	260 "	200 "	380 "	280 "
3/4 - 16	200 "	150 "	300 "	220 "	420 "	320 "
7/8 - 9	170 "	125 "	430 "	320 "	600 "	460 "
7/8 - 14	180 "	140 "	470 "	360 "	660 "	500 "
1 - 8	250 "	190 "	640 "	480 "	900 "	680 "
1 - 12	270 "	210 "	710 "	530 "	1000 "	740 "

Multiply In. Lbs. by (0.113) or Ft. Lbs. by (1.355) for metric Nm.

**NOTE:** These torque values are to be used for all hardware excluding: locknuts, self-tapping screws, thread forming screws, and sheet metal screws. Unless otherwise noted, all torque values must meet this specification.

Attaching Hardware Table

Size & Description	Part Number	Size & Description	Part Number	Size & Description	Part Number	Size & Description	Part Number
#10-24N	650550	5/16LN	071701	3/8FLN	070856	5/8LN	071709
#10L	650549	5/16L	654024	3/8L	654026	5/8L	654032
#12L	650813	5/16P	654004	3/8P	654006	5/8P	654012
1/4LN	071700	3/8N	653010	1/2N	653018	3/4NF-JN	653119
5/16N	653007	3/8JN	653038	1/2LN	071706	3/4L	654034
5/16JN	653034	3/8LN	071703	1/2P	654009	1"P	654016

---

# **GEHL®**

---

## **FARM EQUIPMENT**

**GEHL COMPANY WEST BEND, WISCONSIN 53095 U.S.A.**