

Form No.  
907501

Replaces  
(See NOTE in  
Introduction)

# 329

## Scavenger® II 329 Agricultural Spreader & HD329 Industrial Waste Spreader



## PARTS MANUAL

**GEHL® AGRICULTURE**

## Introduction

When ordering service parts, specify the correct part number, full description, quantity required, the unit model number and serial number.

The Spreader model and serial numbers are on a plate located on the front, left corner of the Tank. "Right" and "Left" are determined from a position standing behind the Spreader and facing in the direction of travel. From this position, the Expeller is on the "right" side.

GEHL® Company reserves the right to make changes or improvements in the design or construction of any part of the unit without incurring the obligation to install such changes on any previously delivered units.

**NOTE:** *On original tire replacement, company policy prohibits the sale of replacement tires for all GEHL machinery. Replacement Wheel Sets are available and tire size information is called out with the Wheel Sets to facilitate replacement tire selection. ALL REPLACEMENT TIRES MUST BE PURCHASED LOCALLY.*

Refer to the abbreviations table located on this page for the various fastener descriptions. Standard attaching hardware torque values are also provided on the inside back cover.

Items shown in the parts list that do not have Reference Numbers are shown for reference purposes only and are NOT available for purchase.

Unless otherwise specified, all Cap Screws or Bolts are Grade 5, cadmium or zinc plated; Hexagon Nuts for Grade 5 Screws or Bolts are Grade B; Hexagon Nuts for other Screws or Bolts are Grade A.

**NOTE:** *The following abbreviations may used herein:*

ASSD	– Assembled
ASSY	– Assembly
CB	– Carriage Bolt
CCW	– Counterclockwise
CP	– Cotter Pin

CS	– Cap Screw (Hexagon Head)
CTR	– Center
CW	– Clockwise
DEG	– Degree
DIA	– Diameter
FCS	– Flanged Cap Screw
FHMS	– Flat Head Machine Screw
FL	– Flanged
FLN	– Flanged Lock Nut (Hexagon)
FLS	– Flanged Lock Screw (Hexagon)
FW	– Flat Washer
GA	– Gauge
GR	– Grade
HD	– Hard or Head
HN	– Hex Nut
INCL	– Includes
JT	– Joint
LG	– Large
LH	– Left Hand
LW	– Lock Washer
LN	– Lock Nut
LW	– Lock Washer
M	– Metric
MM/mm	– Millimeter
NF	– National Fine
PB	– Plow Bolt
PTO	– Power Take Off
RH	– Right Hand
RHMS	– Round Head Machine Screw
RPM	– Revolutions Per Minute
RT	– Right
SERR	– Serrated
SHCS	– Socket Head Cap Screw
SHSS	– Socket Head Set Screw
SN	– Serial Number or Slotted Nut
SQ	– Square
T	– Tooth or Teeth
TFS	– Thread Forming Screw
THMS	– Truss Head Machine Screw
THRD	– Thread
WLDMT	– Weldment

**NOTE:** *This manual replaces **only the Service Parts Chapter** (Chapter 16) of the 329 Operator's and Service Parts Manual, Form# 903870. This manual includes service parts for the HD329, Industrial Waste Spreader.*

*For operation and maintenance information, for either model spreader, refer to Form# 904850.*

# TABLE OF CONTENTS

Introduction .....	Inside Front Cover
Table of Contents .....	1
Decal Locations .....	2–3
Auger Drive .....	4–5
Expeller & Expeller Drive .....	6–7
Discharge Gate, Pan, Auger Slides & Liners .....	8
Gearbox .....	9
Hydraulics	
<b>(After MS329–SN4320 &amp; HD329–SN8599)</b> .....	10–11
<b>(Before MS329–SN4321 &amp; HD329–SN8600)</b> .....	12
Hitch, Jack & Drive Shields .....	13
Tandem Axles & Wheels	
<b>MS329</b> .....	14
<b>HD329</b> .....	15
Universal Drives (PTO's)	
<b>(After MS329–SN4524 &amp; HD329–SN8611)</b> .....	16–17
<b>(Before MS329–SN4525 &amp; HD329–SN8612)</b> .....	18–19
Components	
Auger .....	20
Jack .....	20
Hydraulic Cylinders .....	21
Accessories	
Hydraulic Brakes .....	22–23
Hydraulic Lid .....	24–25
Splash Guards, Side Rails & Safety Chain .....	26
Numerical Index .....	27–29
Index .....	30
Standard Hardware Torque specifications .....	Inside Back Cover

# DECAL LOCATIONS

## GENERAL INFORMATION

Decal Locations information is provided to assist in the proper selection and application of new decals, in the event the original decal(s) become(s) damaged or the machine is repainted. Refer to the listing for the illustration reference number, part number, description and quantity of each decal provided in the Kit. Refer to the appropriate illustration(s) for replacement location(s).

To insure proper selection for correct replacement decal(s), compare all of the various close-up location photographs to your machine BEFORE starting to refinish the unit. Then, circle each pictured decal while checking off its part number in the listing.



## WARNING

**ALWAYS** observe Safety Rules shown on Decals. If Decals become damaged, or if the unit is repainted, replace the Decals. If repainting, **BE SURE** that ALL Decals from the Kit(s) which apply to your machine, are affixed to your unit.

## NEW DECAL APPLICATION

Surfaces **MUST** be free from dirt, dust, grease and other foreign material before applying the new decal. To apply a solid-formed decal, remove the smaller portion of the decal backing paper and apply this part of the exposed adhesive backing to the clean surface while maintaining proper position and alignment. Slowly peel off the other portion of the backing paper while applying hand pressure to smooth out the decal surface.

### PAINT NOTICE

Use this list to order paint for refinishing:

906315*	One Gal. AG Red
901225**	One Gal. Blaze Red
902872*	One Qt. Light Grey
901226**	One Gal. Maize
906316*	6 (12 oz. Spray Cans) AG Red
610239**	6 (12 oz. Spray Cans) Blaze Red
902874*	6 (12 oz. Spray Cans) Light Grey
610240**	6 (12 oz. Spray Cans) Maize

The Decal Set Number for the MS329 and HD329 Spreaders is 112228. The Set includes the Decals which are marked with the † symbol. Order remaining required Decals individually by part number. Safety related Decals are shown in **BOLD** text.

Ref. No.	Part No.	Description & Quantity
1	047272†	SMV (Slow Moving Vehicle)
2	060510†	Jack Storage Position
3	060511†	Jack Lifting Position
4	067493†	Red Reflector Strip (2 Places)
5	<b>091442†</b>	<b>DANGER – Rotating Auger (2 Places)</b>
6	<b>091444†</b>	<b>DANGER – Rotating Drive Line</b>
7	093020†	Lubrication Symbol (5 Places)
8	093208†	Rotating Symbol (2 Places)
9	<b>093365†</b>	<b>WARNING – Close or Replace Guard (2 Places)</b>
10	093366†	IMPORTANT - Store Manual Here
11	<b>093367†</b>	<b>WARNING – Owner's Responsibility &amp; Read Manual</b>
12	<b>093373†</b>	<b>WARNING – General Safety Precautions</b>
13	<b>093465†</b>	<b>WARNING – 1000 RPM Operation Only</b>
	<b>093466†</b>	<b>WARNING – 540 RPM Operation Only</b>
14	<b>093638†</b>	<b>DANGER – Rotating Expeller (2 Places)</b>
15	<b>093639†</b>	<b>DANGER – Manure Gas</b>
16	<b>093653†</b>	<b>WARNING – Rotating Drive Line</b>
17	094911†*	Scavenger II (2 Places)
	081467**	Scavenger II (2 Places)
18	094912†*	Colorbar 12" (2 Places)
19	094913†*	GEHL 3–1/4" (3 Places)
	080124**	GEHL (4 Places)
20	094951†	Made in USA
21	094969*	329 (2 Places - MS329 ONLY)
	080254**	329 (2 Places)
	094975*	HD329 (2 Places - HD329 ONLY)
22	080491	Patent
	080247**	NO STEP (Not shown – located on early style PTO Shield)

† Included in Decal Set 112228.

\* Used **AFTER MS329–SN4499 & HD329–SN8599**.

\*\* Used **BEFORE MS329–SN4500 & HD329–SN8600**.

**NOTE:** Order (as required) Part Number 126757 for a 10 foot roll of 3/4" Grey Striping\*.

**NOTE:** Order (as required) Part Number 090909 for a 50 foot roll of 4–1/2" Yellow and Black Striping\*\*.

**NOTE:** Refer to the **SAFETY** Chapter of the Operator's Manual for the specific information provided on all of the various Safety Decals furnished in the Decal Kit.

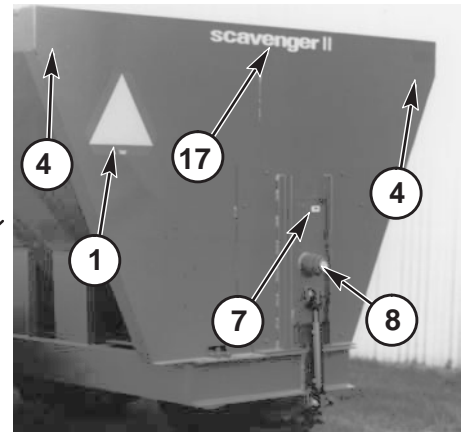
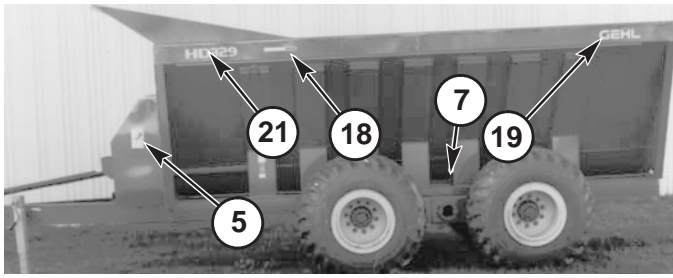

HD329 Shown (Typical)



Rear Master

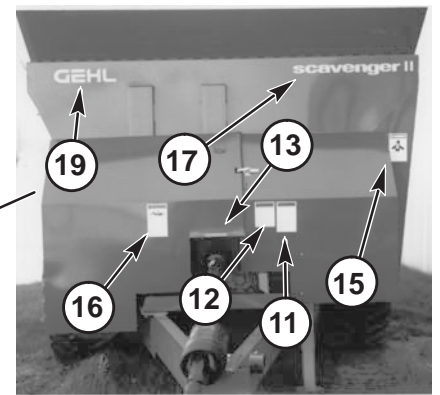
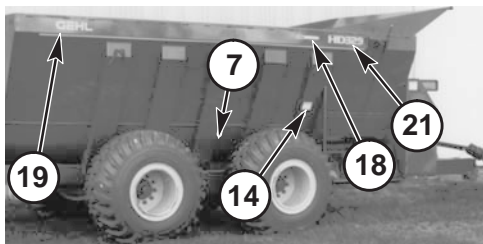
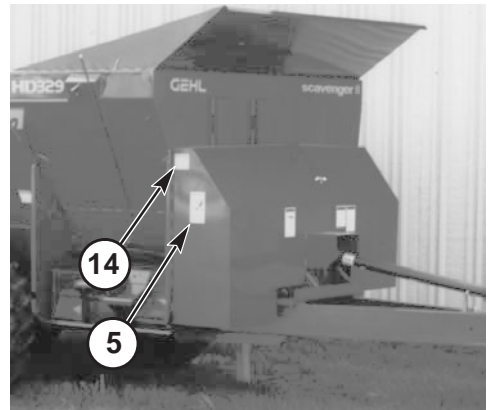
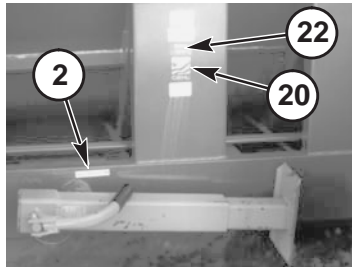
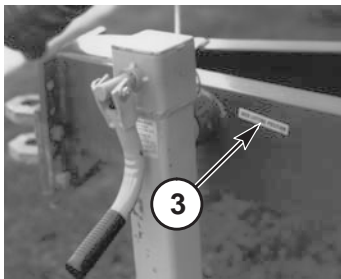

Front Master

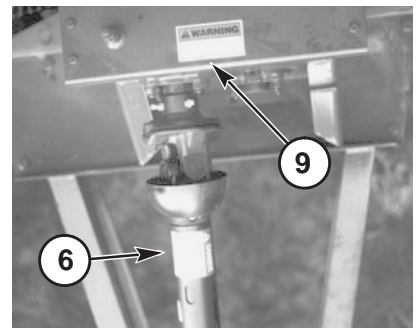
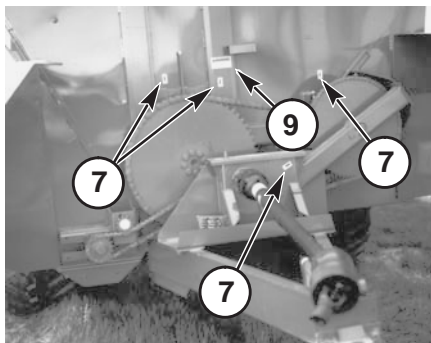

# 329 – AUGER DRIVE

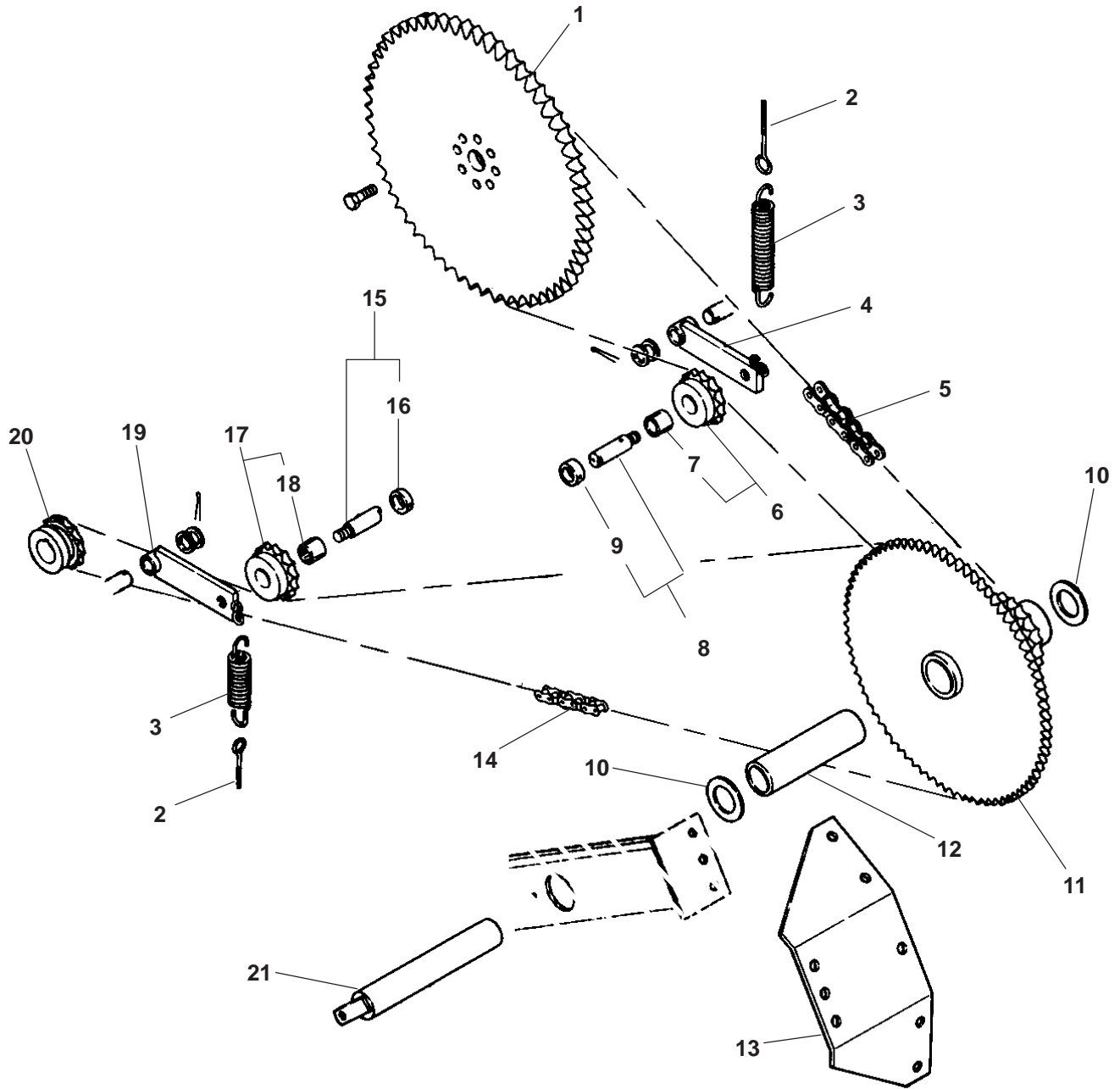

## 329 – AUGER DRIVE

Ref. No.	Part No.	Description	Qty. Req.	Ref. No.	Part No.	Description	Qty. Req.
01	080397	SPROCKET/ASSY#120X60T .....	1	11	083258	SPROCKET/JACKSHAFT ASSY .....	1
	651090	CS 3/4X2 GR 8 (L) .....	8		570002	FITTING/GREASE .....	1
02	095026	EYEBOLT/3/8X3-3/4 .....	2	12	088695	BUSHING/BRONZE .....	1
		(USED AFTER <b>MS329-SN4312&amp; HD329-SN8599</b> )		13	080846	BRACE/JACKSHAFT .....	1
		(2) 3/8 LN, P			650307	CS 5/8X1-1/2 (N, L, P) .....	8
	066172	EYEBOLT/5/16X4 .....	2	14	606662 <sub>b</sub>	CHAIN/ROLLER (#80 X 98 LINKS) .....	1
		(USED BEFORE <b>MS329-SN4313&amp; HD329-SN8600</b> )		15	082263	SHAFT/IDLER (INCL REF. 16) .....	1
		(3) 5/16 LN, P			570005	FITTING/GREASE .....	1
03	080645	SPRING/EXTENSION .....	2	16	S 16174	COLLAR/SET .....	1
04	083257	ARM/IDLER ASSY .....	1		650201	SHSS 5/16X5/16 .....	1
	655020	PIN/COTTER 3/16X1-1/2 .....	1	17	080644	SPROCKET/IDLER 12T (INCL REF. 18) .	1
		(1) 1P		18	H 8352A	BUSHING .....	1
05	094952 <sub>a</sub>	CHAIN/ROLLER (#120HE X 88 LINKS) .....	1	19	080616	ARM/IDLER ASSY .....	1
06	606666	SPROCKET/IDLER 11T (INCL REF. 07) .	1		655020	PIN/COTTER 3/16X1-1/2 .....	AR
07	081500	BUSHING/BRONZE .....	1			(AR) 1P	
08	080615	SHAFT/IDLER (INCL REF. 09) .....	1	20	606671 <sub>c</sub>	SPROCKET/12T .....	1
	570005	FITTING/GREASE .....	1	21	083259	JACKSHAFT/ASSY .....	1
09	081501	COLLAR/SET .....	1		650731	CS 3/8X3-1/2 (LN) .....	1
	650212	SHSS 3/8X3/8 .....	1				
10	080834	WASHER/SHIM .....	AR				

- a) Includes 141155 Plain Connector Link.
- b) Includes 500195 Plain Connector Link.
- c) This Sprocket attaches to the Gearbox as illustrated on page titled GEARBOX, Ref. 11.

# 329 – EXPELLER & EXPELLER DRIVE

\* Ref. 7

A = 4-1/8" (For R13216 Bearing Housing)

A = 4-3/8" (For 606734 Bearing Assembly)

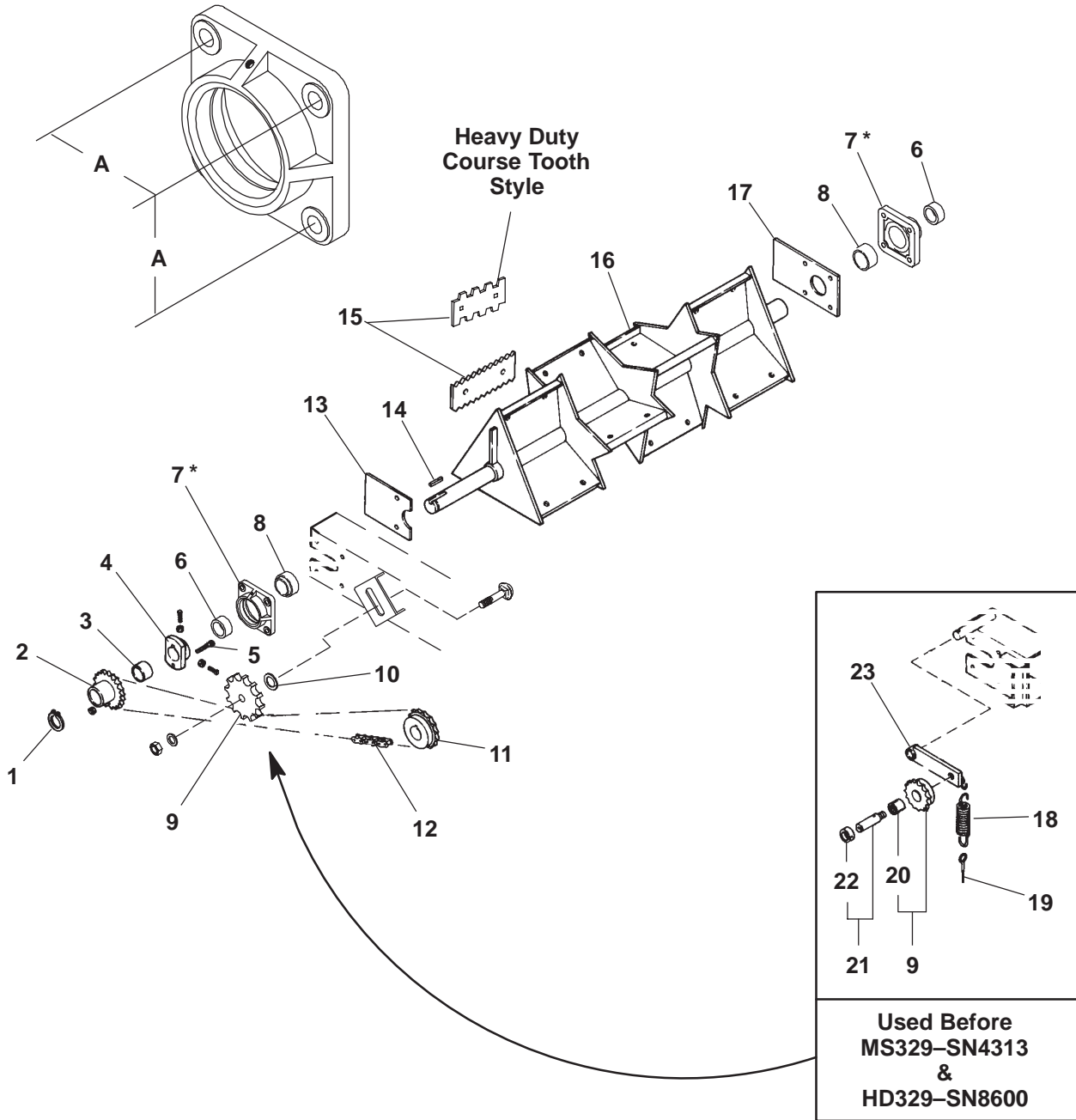

## 329 – EXPELLER & EXPELLER DRIVE

Ref. No.	Part No.	Description	Qty. Req.	Ref. No.	Part No.	Description	Qty. Req.
01	606465	RING/RETAINING	1	12	606663 <sub>e</sub>	CHAIN/ROLLER (1000 RPM)	
02	113034	SPROCKET/ASSY 17T (INCL REF. 03)	1			(#80 X 82 LINKS)	1
03	045171	BUSHING/BRONZE	1		083277 <sub>e</sub>	CHAIN/ROLLER (540 RPM)	
04	083669	FLANGE/SHEAR	1			(#80 X 88 LINKS)	1
		(USED ON ALL 1000 RPM & ON 540 RPM AFTER MS329-SN4524)		13	080631	PLATE/FRONT	1
	650231	SQHSS 3/8X1 (JN)	2		650494	CS 1/2X1 (N, L, P)	2
	080598	FLANGE/SHEAR (540 RPM)	1	14	056230	KEY/SQUARE 3/8SQX2	1
		(USED BEFORE MS329-SN4525)		15	080233	TEETH/EXPELLER REEL	12
	651029	SQHSS-CP 5/16X1 (JN)	2		650495	CS 1/2X1-1/4 (FLN)	24
05	077066 <sub>a</sub>	BOLT/SHEAR 1/4X1-1/2 GR 5	1		094474	TEETH/EXPELLER REEL	
		(USED ON ALL 1000 RPM & ON 540 RPM AFTER MS329-SN4524)				(OPTIONAL – HEAVY DUTY)	12
		(1) 1/4 LN			650527	CB 1/2X1-1/4 (FLN)	24
	080454 <sub>b</sub>	BOLT/SHEAR 5/16X2 GR 5 (540 RPM)	1	16	094550	EXPELLER/ASSY 4 POCKET	1
		(USED BEFORE MS329-SN4525)		17	080630	PLATE/EXPELLER REAR	1
		(1) 5/16 LN		18	080645	SPRING/EXTENSION	1
06	520195	COLLAR/BEARING	2			(USED BEFORE MS329-SN4313 & HD329-SN8600)	
		(USED ONLY W/ 4-1/8" STYLE BEARING)		19	066172	EYEBOLT/5/16X4	3
07	R13216 <sub>c</sub>	HOUSING/BEARING	2			(USED BEFORE MS329-SN4313 & HD329-SN8600)	
		(USED AFTER MS329-SN4540)				(3) 5/16 LN, P	
	650569	CS 1/2X1-3/4 (LN, P)	8	20	520132	BEARING/NEEDLE	1
	570002	FITTING/GREASE	2			(USED BEFORE MS329-SN4313 & HD329-SN8600)	
	606734 <sub>d</sub>	FLANGE/BEARING (INCL REF. 08)	2	21	080617	SHAFT/IDLER (INCL REF. 22)	1
		(USED BEFORE MS329-SN4541 & ON ALL HD329)				(USED BEFORE MS329-SN4313 & HD329-SN8600)	
	650569	CS 1/2X1-3/4 (LN, P)	8		570005	FITTING/GREASE	1
	570002	FITTING/GREASE	2	22	S 16174	COLLAR/SET	2
08	520194 <sub>g</sub>	BEARING/BALL (INCL REF. 06)	2			(USED BEFORE MS329-SN4313 & HD329-SN8600)	
		(USED AFTER MS329-SN4540)			650201	SHSS 5/16X5/16	2
	606308 <sub>g</sub>	BEARING/BALL (INCL REF. 06)	2	23	080616	ARM/IDLER ASSY	1
		(USED BEFORE MS329-SN4541 & ON ALL HD329)				(USED BEFORE MS329-SN4313 & HD329-SN8600)	
09	091918	SPROCKET/IDLER ASSY #80X12T	1		655020	PIN/COTTER 3/16X1-1/2	AR
		(USED AFTER MS329-SN4312 & HD329-SN8599)				(AR) 1P	
	651292	CB 3/4X3 (LN)	1				
		(AR) 3/4 P					
	082020	SPROCKET/IDLER 13T (INCL REF. 20)	1				
		(USED BEFORE MS329-SN4313 & HD329-SN8600)					
10	099242	BUSHING	AR				
		(USED AFTER MS329-SN4312 & HD329-SN8599)					
11	082022 <sub>f</sub>	SPROCKET/14T (1000 RPM)	1				
	082021 <sub>f</sub>	SPROCKET/26T (540 RPM)	1				
	650201	SHSS 5/16X5/16	2				

- a) For replacement Shear Bolts, order 900084 which contains four each 077066 Bolts and Lock Nuts.
- b) For replacement Shear Bolts, order 080455 which contains eight each 080454 Bolts and Lock Nuts.
- c) Has 4-1/8" square mounting hole pattern.
- d) Has 4-3/8" square mounting hole pattern.
- e) Includes 500195 Plain Connector Link.
- f) This Sprocket attaches to the Gearbox as illustrated on page titled GEARBOX, Ref. 13.
- g) Some units were built with a 90mm OD Bearing. For Bearing replacement order 606309. For Bearing and Housing replacement, order 606308 & 606734.

# 329 – DISCHARGE GATE, PAN, AUGER SLIDES & LINERS

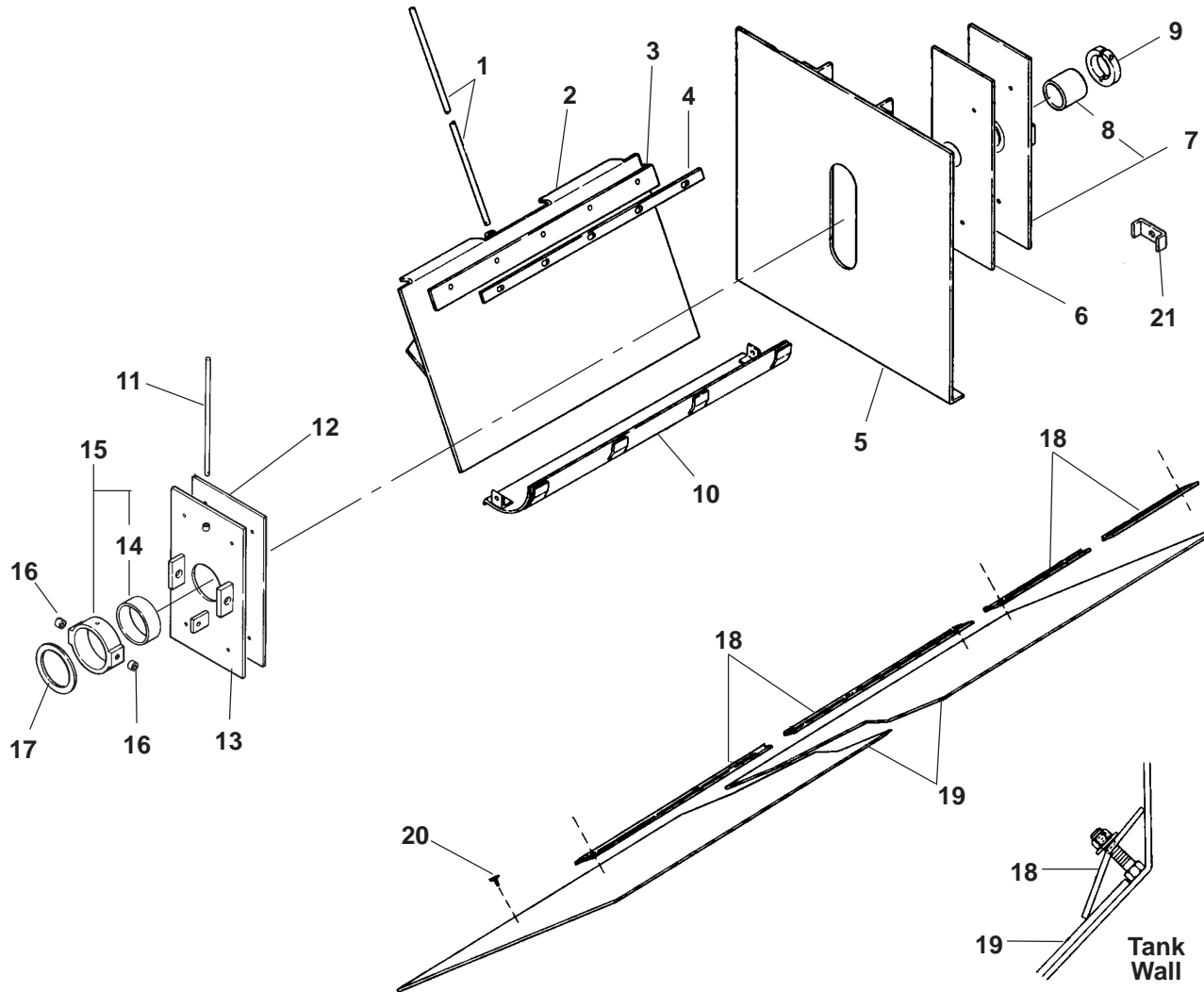

**Liner Mounting Detail**

Ref. No.	Part No.	Description	Qty. Req.	Ref. No.	Part No.	Description	Qty. Req.
01	083226	ROD/GATE	1	11	606941	ROD/AUGER	1
	655048	PIN/COTTER 5/32X1-1/4	1		655048	PIN/COTTER 5/32X1-1/4	1
02	094807	GATE/ASSY	1	12	083252	LINER/FRONT	1
03	082010	WIPER/RUBBER	1	13	083253	PLATE/AUGER SLIDE ASSY FRONT	1
04	082011	WIPER/RETAINER	1		570005	FITTING/GREASE	4
		(5) 3/8 LN, P		14	083256	BUSHING/BRONZE	1
05	083229	PLATE/REAR ASSY	1	15	083255	TRUNNION ASSY (INCL REF. 16)	1
06	083228	LINER/REAR	1		570012	FITTING/GREASE	1
07	083227	SLIDE/AUGER ASSY (INCL REF. 08)	1	16	606676	BUSHING/BRONZE	2
	570002	FITTING/GREASE	3		651187	CS 3/4X1-3/4 (P)	2
08	080605	BUSHING/BRONZE	1	17	083254	SPACER	1
09	088749	COLLAR/LOCK	1	18	080674	HOLDDOWN/LINER	2
	650896	SHCS 5/16X1-1/4	1			(AR) 3/8 FLN	
10	082016	PAN/EXPELLER REEL	1	19	081742	LINER/POLYMER 191X60	1
	650545	CS 5/16X1-1/4 (LN)	2	20	651069	BOLT/ELEVATOR	8
				21	080626	CLIP/AUGER PLATE	11
						(11) 1/2 LN	

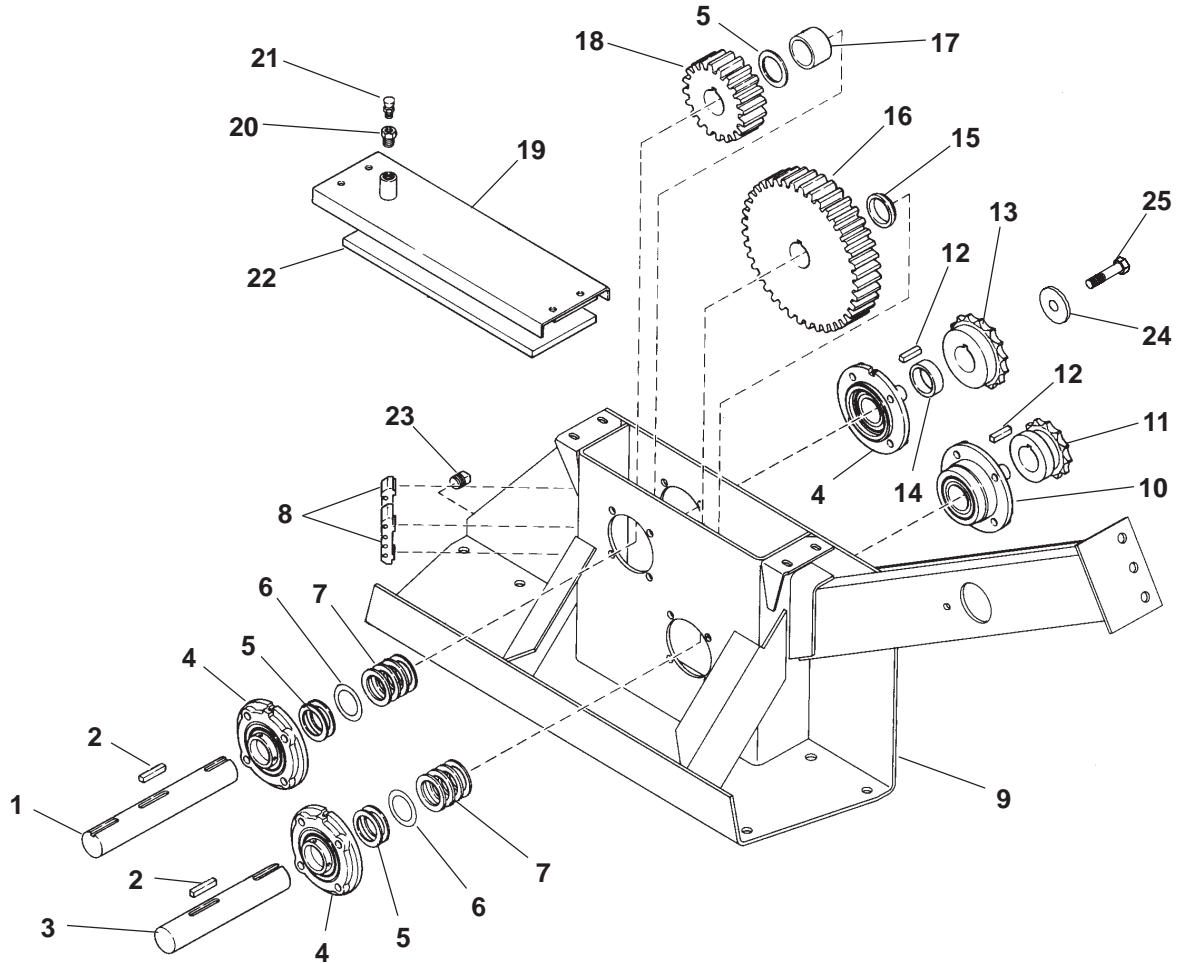

Ref. No.	Part No.	Description	Qty. Req.	Ref. No.	Part No.	Description	Qty. Req.
01	083287	SHAFT/LONG (INPUT) .....	1	13	082022	SPROCKET/#80X14T (1000 RPM) .....	1
02	056230	KEY/SQUARE 3/8SQX2 .....	2		082021	SPROCKET/#80X26T (540 RPM) .....	1
03	083288	SHAFT/SHORT (OUTPUT) .....	1	14	083283	SPACER .....	1
04	606541	BEARING/FLANGE .....	3	15	083284	SPACER .....	1
	650585	CS 1/2X2 (N, L) .....	12	16	606672	GEAR/40T (1000 RPM) .....	1
05	083281	SHIM .....	AR		606542	GEAR/30T (540 RPM) .....	1
06	042858	SHIM .....	AR	17	083282	SPACER .....	1
07	083289	SHIM .....	AR	18	606673	GEAR/20T (1000 RPM) .....	1
08	059272	HOLDER/SHEAR BOLT .....	2		606542	GEAR/30T (540 RPM) .....	1
09	080595	HOUSING/GEARBOX .....	1	19	083285	COVER/GEARBOX ASSY .....	1
	650307	CS 5/8X1-1/2 (N, L, P) – (FOR MOUNTING GEARBOX TO FRAME) ..	8		650491	CS 3/8X1-1/4 (N, L, P) .....	4
10	606678	BEARING/FLANGE .....	1	20	660044	BUSHING/REDUCER 1/2X1/8 .....	1
	650452	CS 7/16X1-1/2 (N, L) .....	4	21	045668	BREATHER .....	1
	570004	FITTING/GREASE .....	1	22	080845	GASKET/GEARBOX COVER .....	1
11	606671	SPROCKET/#80X12T .....	1	23	660004	PLUG/PIPE 1/2 .....	1
12	059566	KEY/SQUARE 3/8SQX1-1/2 .....	2	24	057557	WASHER .....	1
				25	650495	CS 1/2X1-1/4 (L) .....	1

329 – HYDRAULICS (AFTER MS329–SN4320 & HD329–SN8599)

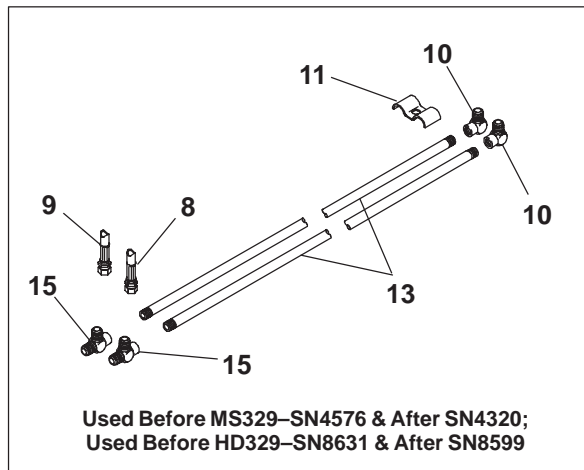
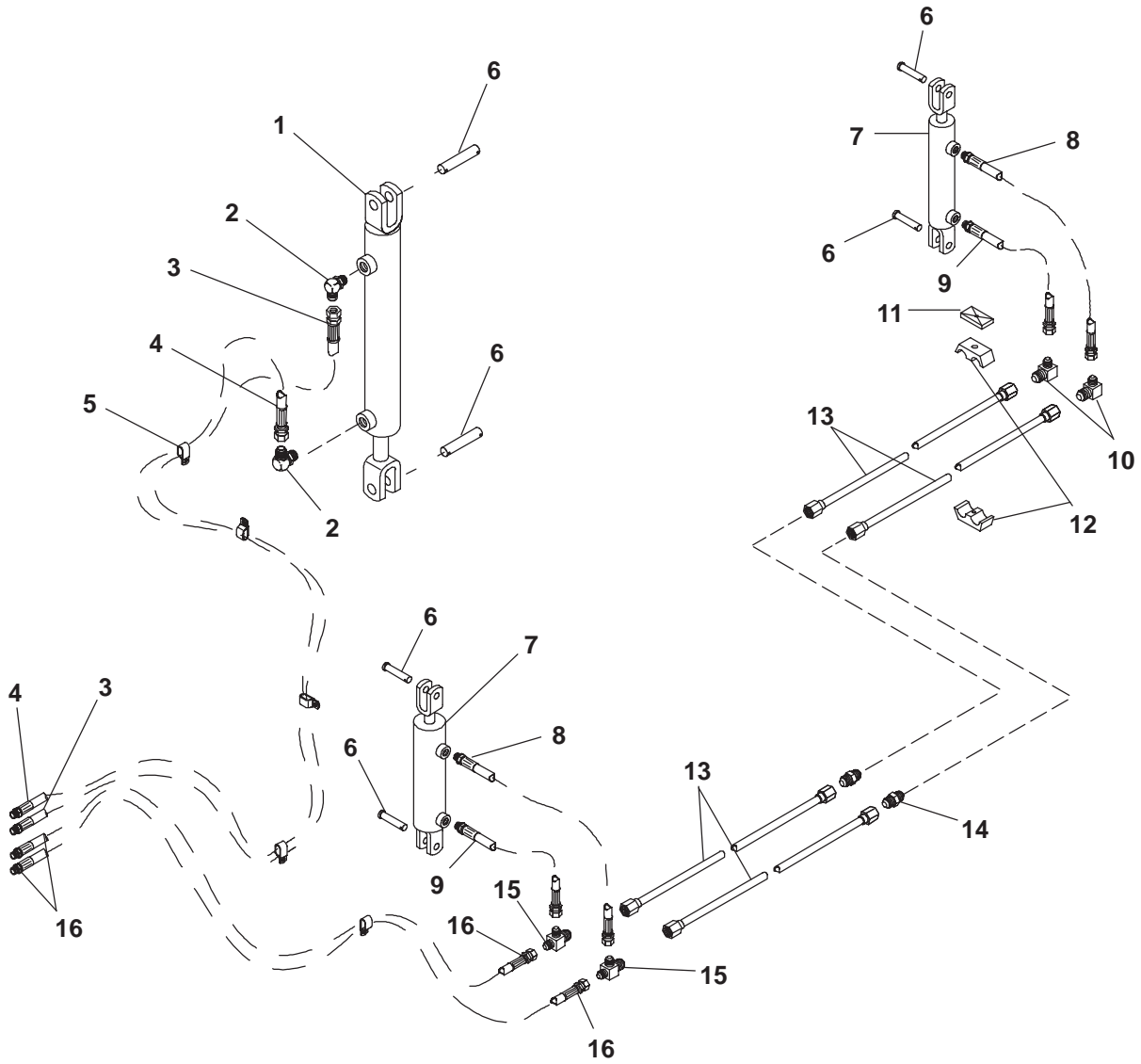

## 329 – HYDRAULICS (AFTER MS329–SN4320 & HD329–SN8599)

Ref. No.	Part No.	Description	Qty. Req.	Ref. No.	Part No.	Description	Qty. Req.
01	095146 <sub>a</sub>	CYLINDER/GATE .....	1	12	088904	CLAMP/TUBE .....	3
02	068938	ELBOW/90 DEG ADJUSTABLE .....	2			(USED AFTER <b>MS329–SN4575</b> ; USED AFTER <b>HD329–SN8630</b> )	
03	095147	HOSE 1/2NPT X 9/16JIC X 204 .....	1	13	119693	TUBE/HYD. 96–3/4 LONG (W/NUTS) ...	4
04	095148	HOSE 1/2NPT X 9/16JIC X 195 .....	1			(USED AFTER <b>MS329–SN4575</b> ; USED AFTER <b>HD329–SN8630</b> )	
05	055021	CLAMP/DOUBLE HOSE .....	5				
		(5) 3/8LN					
06	083232	PIN/CYLINDER .....	6		110051	TUBE/HYD. 3/8NPT X 195 .....	2
	655046	CP 5/32x1–3/4 .....	12			(USED AFTER <b>MS329–SN4320</b> & BEFORE <b>SN4576</b> ; USED AFTER <b>HD329–SN8599</b> & BEFORE <b>SN8631</b> )	
07	095145 <sub>a</sub>	CYLINDER/AUGER 2X8 .....	2	14	087107	CONNECTOR/UNION 3/4JIC .....	2
08	095150	HOSE 9/16O–RING X 9/16JIC X 28 .....	2			(USED AFTER <b>MS329–SN4575</b> ; USED AFTER <b>HD329–SN8630</b> )	
09	095151	HOSE 9/16O–RING X 9/16JIC X 26 .....	2	15	119258	TEE/JIC(9/16X9/16X3/4) .....	2
10	119257	ELBOW/90 DEG 3/4JIC X 9/16JIC .....	2			(USED AFTER <b>MS329–SN4575</b> ; USED AFTER <b>HD329–SN8630</b> )	
	110448	ELBOW/90 DEG 3/8NPT X 9/16JIC .....	2		097307	TEE(9/16JICX9/16JICX3/8NPT) .....	2
		(USED AFTER <b>MS329–SN4320</b> & BEFORE <b>SN4576</b> ; USED AFTER <b>HD329–SN8599</b> & BEFORE <b>SN8631</b> )				(USED AFTER <b>MS329–SN4320</b> & BEFORE <b>SN4576</b> ; USED AFTER <b>HD329–SN8599</b> & BEFORE <b>SN8631</b> )	
11	079098	PLATE/TWIN COVER .....	3	16	095149	HOSE 1/2NPT X 9/16JIC X 144 .....	2
		(USED AFTER <b>MS329–SN4575</b> ; USED AFTER <b>HD329–SN8630</b> )					
	650692	CS 5/16X1–3/4 (LN, P) .....	3				
	018453	CLAMP/HOSE .....	2				
		(USED BEFORE <b>MS329–SN4576</b> ; USED BEFORE <b>HD329–SN8631</b> )					
		(2) 3/8 FLN					

a) For repair parts, see page titled COMPONENTS, HYDRAULIC CYLINDERS.

# 329 – HYDRAULICS (BEFORE MS329–SN4321 & HD329–SN8600)

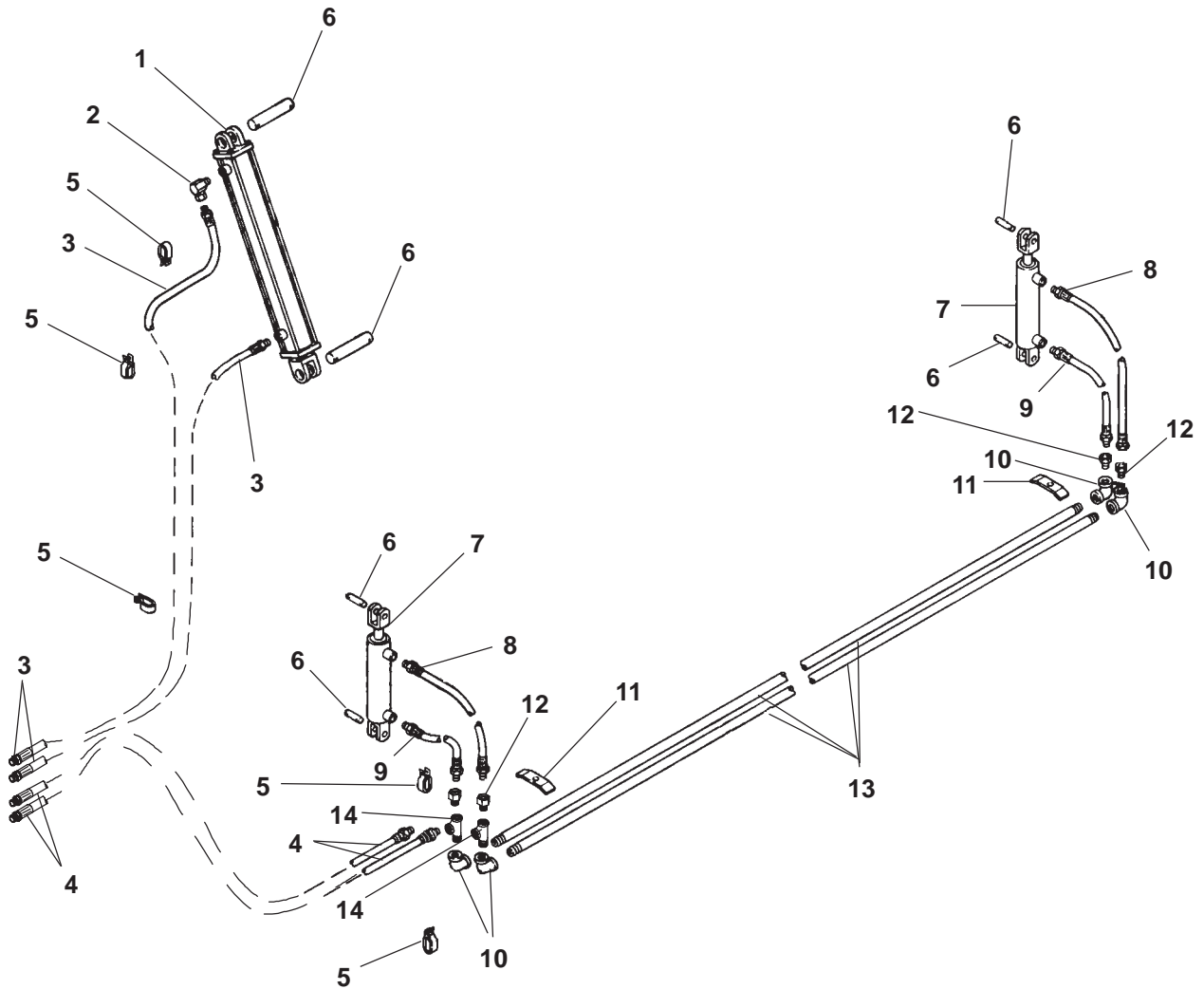

Ref. No.	Part No.	Description	Qty. Req.	Ref. No.	Part No.	Description	Qty. Req.
01	606086 <sub>a</sub>	CYLINDER/GATE 2X18 .....	1	09	083231	HOSE 1/2NPT X 3/8NPT X 26 .....	2
02	580049	FITTING/SWIVELBOW .....	1	10	660009	ELBOW/90 DEG 1/2 NPT .....	4
03	083250	HOSE 1/2NPT X 3/8NPT X 204 .....	2	11	018453	CLAMP/HOSE .....	2
04	083251	HOSE 1/2NPT X 1/2NPT X 144 .....	2			(2) 3/8 FLN	
05	055021	CLAMP/DOUBLE HOSE .....	5	12	580058	SWIVEL/ADAPTER 1/2 NPT .....	4
		(5) 3/8LN		13	081424 <sub>b</sub>	PIPE/HYD. 1/2NPT X 195 .....	2
06	083232	PIN/CYLINDER .....	6	14	660079	TEE/PIPE 1/2 NPT .....	2
	655046	CP 5/32x1-3/4 .....	12				
07	606099 <sub>a</sub>	CYLINDER/AUGER 2X8 .....	2				
08	083230	HOSE 1/2NPT X 3/8NPT X 28 .....	2				

a) For repair, order 090033 Seal Kit.  
 b) Purchase locally.

# 329 – HITCH, JACK & DRIVE SHIELDS

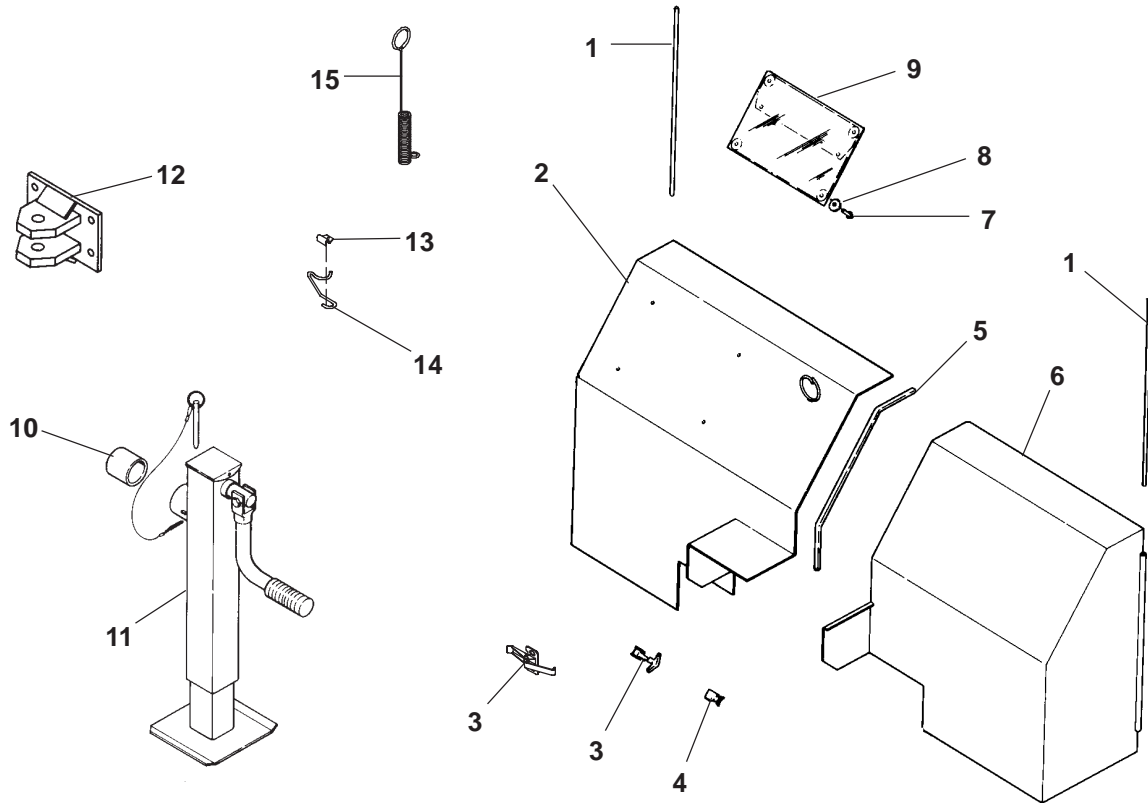

Ref. No.	Part No.	Description	Qty. Req.	Ref. No.	Part No.	Description	Qty. Req.
01	084253	ROD/HINGE .....	2	08	068642	WASHER .....	4
01	655006	PIN/COTTER 1/8X1 .....	2	09	078580	POUCH/MANUAL .....	1
02	084254	SHIELD/RIGHT HALF .....	1	10	081954	HUB/JACK (WELD-ON) .....	2
03	080648	LATCH/METAL (LATER STYLE) .....	1	11	082027 <sub>a</sub>	JACK/ASSY .....	1
	650953	RHMS 1/4X1/2 (LN) .....	2	12	082012	HITCH/DRAWBAR ASSY .....	1
	080648	LATCH/RUBBER (EARLY STYLE) .....	1		650647	CS 5/8X2 (LN) .....	4
		(USES REF. 04)		13	116786	BRACKET/PIVOT .....	1
	650815	RHMS #10-24X3/4 (N, L) .....	2		650490	CS 3/8X1 (LN) .....	1
04	081087	KEEPER/LATCH .....	1	14	116787	ROD/PTO SUPPORT .....	1
	650548	RHMS #10-24X1/2 (N, L) .....	2	15	110032	SUPPORT/SPRING .....	1
05	084255	STRIP/TRIM .....	1		650490	CS 5/8X1-1/2 (P, LN) .....	1
06	084256	SHIELD/LEFT HALF .....	1				
07	075274	RIVET/BLIND .....	4				

a) For serviceable components, see page titled COMPONENTS, AUGER & JACK.

# MS329 – TANDEM AXLES & WHEELS

Used on MS329, only

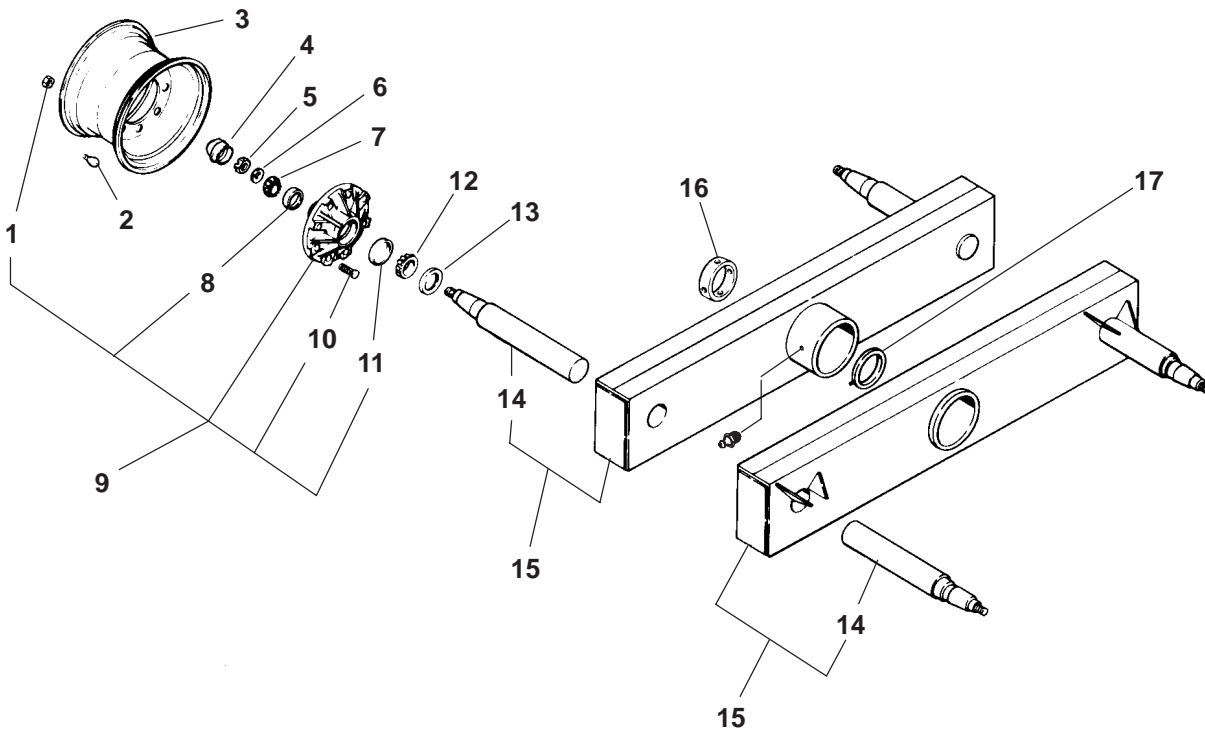

Ref. No.	Part No.	Description	Qty. Req.	Ref. No.	Part No.	Description	Qty. Req.
01	079152	NUT/WHEEL .....	32	10	083107	BOLT/STUD WHEEL .....	32
02	045581	STEM/VALVE .....	4	11	520013	CUP/BEARING-INNER .....	4
03	112445	WHEEL W14C X 16.1 .....	4	12	083108	CONE/BEARING-INNER .....	4
		(FOR 19L X 16.1 TIRE)		13	083109	SEAL/GREASE .....	4
	112446	WHEEL W16C X 16.1 .....	4	14	083105	SPINDLE 3X23 (WELD-ON) .....	4
		(FOR 21.5L X 16.1 TIRE)			655022	PIN/COTTER 3/16X1-3/4 .....	4
04	003938	CAP/GREASE .....	4	15	095112	AXLE/TANDEM ASSY .....	2
05	650933	NUT/SLOTTED 1-12NF .....	4			(INCL. 2 EACH REF. 14)	
06	003943	WASHER .....	4		570002	FITTING/GREASE .....	4
07	042163	CONE/BEARING-OUTER .....	4	16	606730	TUBE/RETAINER .....	2
08	042162	CUP/BEARING-OUTER .....	4		650882	CS 1/2X8 (LN) .....	2
09	083106	HUB/WHEEL (7500# CAPACITY) .....	4	17	606142	TUBE/SPACER .....	2
		(INCL. REF. 01, 08, 10 & 11)					

# HD329 – TANDEM AXLES

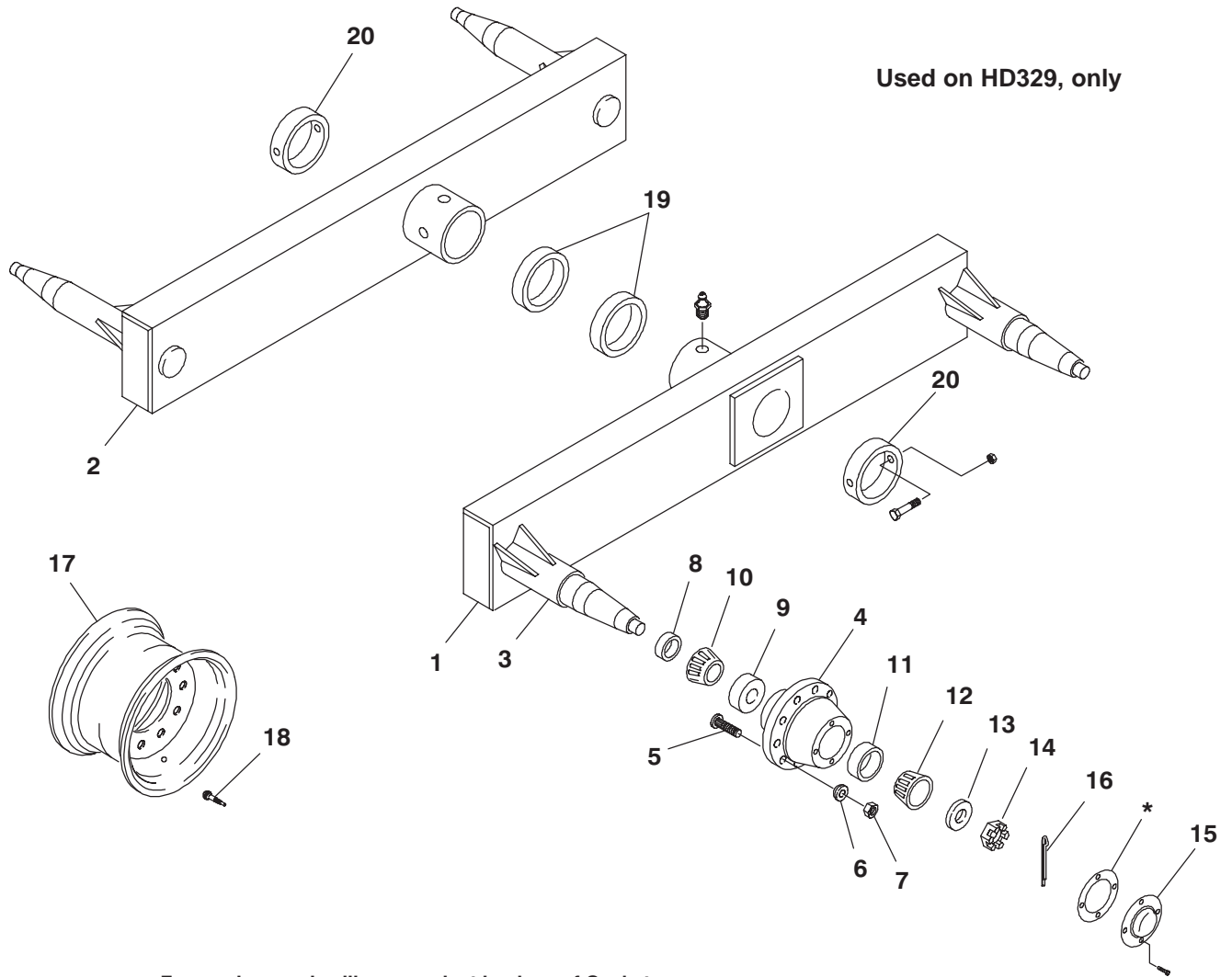

\* For service, apply silicone sealant in place of Gasket

Ref. No.	Part No.	Description	Qty. Req.	Ref. No.	Part No.	Description	Qty. Req.
01	094797	AXLE/TANDEM ASSY LT	1	11	112190	CUP/BRG (OUTER)	4
		(INCL. 2 EACH REF. 03)		12	112191	CONE/BRG (OUTER)	4
	570002	FITTING/GREASE	2	13	112192	WASHER/SPINDLE	4
02	094796	AXLE/TANDEM ASSY RT	1	14	112193	NUT/SPINDLE 1-3/4NF	4
		(INCL. 2 EACH REF. 03)		15	112195	CAP/DUST	4
	570002	FITTING/GREASE	2		650481	CS 1/4X1/2	16
03	094802	SPINDLE 4X22-1/2 (WELD IN)	4	16	655033	PIN/COTTER 5/16X3-1/2	4
04	094803	16000# HUB ASSEMBLY	4	17	117499	WHEEL/20X20.5	4
		(INCL 05, 06, 07, 09, 11, 15 & GASKET *)		18	045581	VALVE/TIRE	4
05	112184	STUD/WHEEL	40	19	606142	TUBE/SPACER	2
06	112185	WASHER/STUD	40	20	606730	TUBE/RETAINER	2
07	112186	NUT/WHEEL	40		650502	CS 1/2X2-1/4 (NILN)	4
08	112187	SEAL/OIL	4	*	N/A	GASKET/DUST CAP	4
09	112188	CUP/BRG (INNER)	4				
10	112189	CONE/BRG (INNER)	4				

\* For service, apply silicone sealant to Dust Cap, Ref. 15.

329 – UNIVERSAL DRIVES (AFTER MS329–SN4524 & HD329–SN8611) \_\_\_\_\_

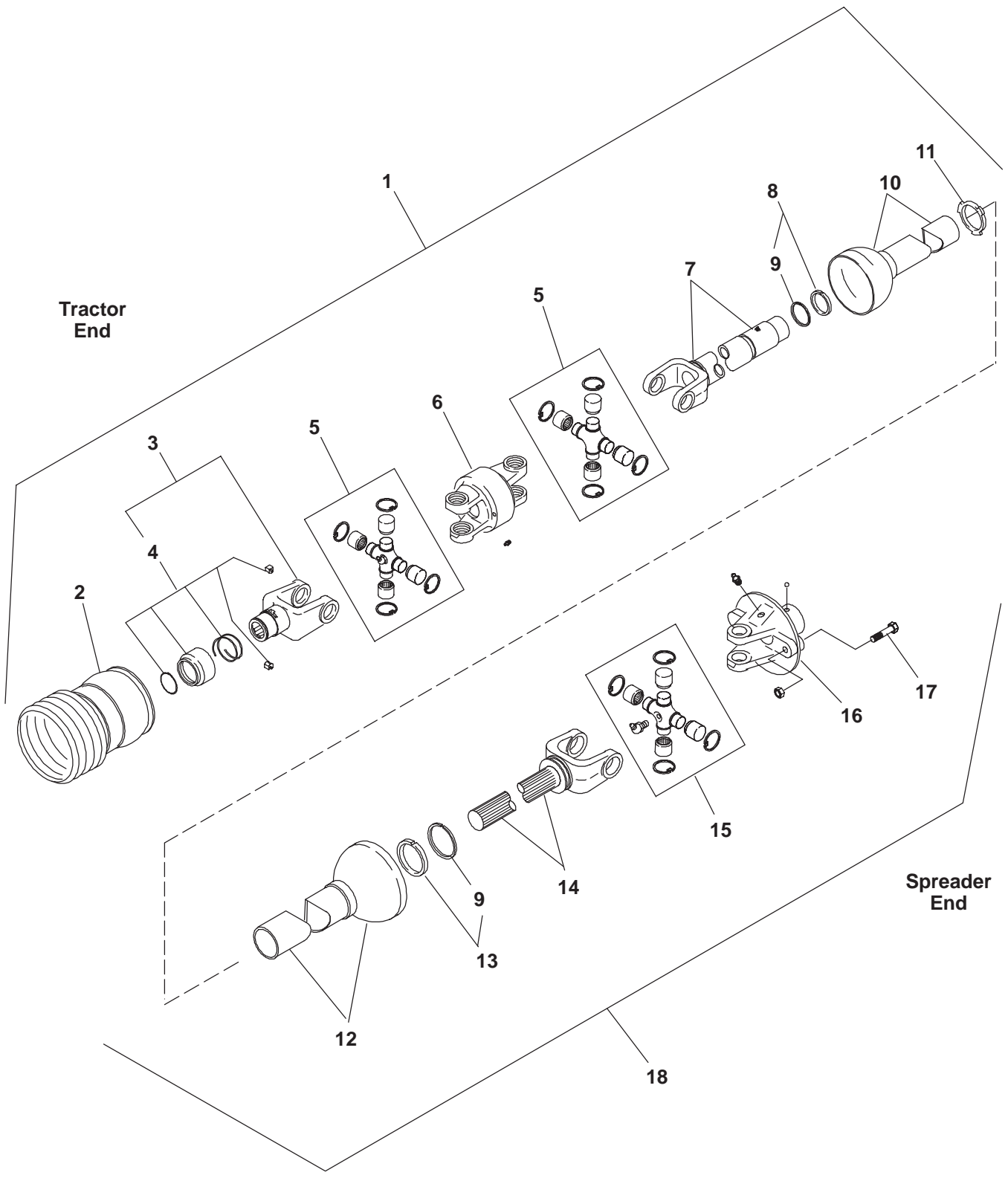

## 329 – UNIVERSAL DRIVES (AFTER MS329–SN4524 & HD329–SN8611)

Ref. No.	Part No.	Description	Qty. Req.	Ref. No.	Part No.	Description	Qty. Req.
01	084235	PTO/TRACTOR HALF ASMD ..... 1 (540 RPM)	1	13	095130	KIT/REPAIR (INCL REF. 09) ..... 1	1
	084246	PTO/TRACTOR HALF ASMD ..... 1 (1000 RPM)	1	14	112772	YOKE & SHAFT/ASSY ..... 1	1
02	088818	GUARD/PLASTIC ..... 1	1	15	045857	KIT/CROSS ..... 1	1
03	084240	YOKE/SLIDE LOCK ASSY (540 RPM) .. 1 (INCL REF. 04)	1		570009	FITTING/GREASE ..... 1	1
	084248	YOKE/SLIDE LOCK ASSY (1000 RPM) . 1 (INCL REF. 04)	1	16	112774	BALL/SHEAR ASSY (540 RPM) ..... 1	1
04	095166	KIT/SLIDE LOCK ..... 1	1		112771	BALL/SHEAR ASSY (1000 RPM) ..... 1 (INCL REF. BALL REPAIR KIT 112767)	1
05	084241	KIT/CROSS ..... 2	2		650906	SQHSS 3/8X1 (JN) ..... 2	2
	570009	FITTING/GREASE ..... 2	2		570002	FITTING/GREASE ..... 1	1
06	084239	HOUSING/CENTER ASSY ..... 1	1	17	062371 <sub>a</sub>	BOLT/SHEAR 5/16X1–3/4 GR 8 ..... 1 (540 RPM)	1
	570014	FITTING/GREASE ..... 1	1			(1) 5/16LN	
07	084238	YOKE & TUBE/ASSY ..... 1	1		080452 <sub>b</sub>	BOLT/SHEAR 1/4X2 GR 5 ..... 1 (1000 RPM)	1
	570001	FITTING/GREASE (LONG) ..... 1	1			(1) 1/4LN	
	570002	FITTING/GREASE ..... 1	1	18	112764	PTO/MACHINE HALF ASMD ..... 1 (540 RPM)	1
08	095132	KIT/REPAIR (INCL REF. 09) ..... 1	1		112753	PTO/MACHINE HALF ASMD ..... 1 (1000 RPM)	1
09	510100	RETAINER/BEARING ..... 2	2				
10	084237	SHIELD/TRACTOR HALF ..... 1 (INCL REF. 02)	1				
11	084242	BEARING/CENTRALIZER ..... 1	1				
12	112773	SHIELD/MACHINE HALF ..... 1	1				

**a)** For replacement Shear Bolts, order Kit 901606 which contains eight each 062371 Bolt and 071703 Lock Nut.

**b)** For replacement Shear Bolts, order Kit 080453 which contains eight each 080452 Bolt and 071700 Lock Nut.

329 – UNIVERSAL DRIVES (BEFORE MS329–SN4525 & HD329–SN8612) \_\_\_\_\_

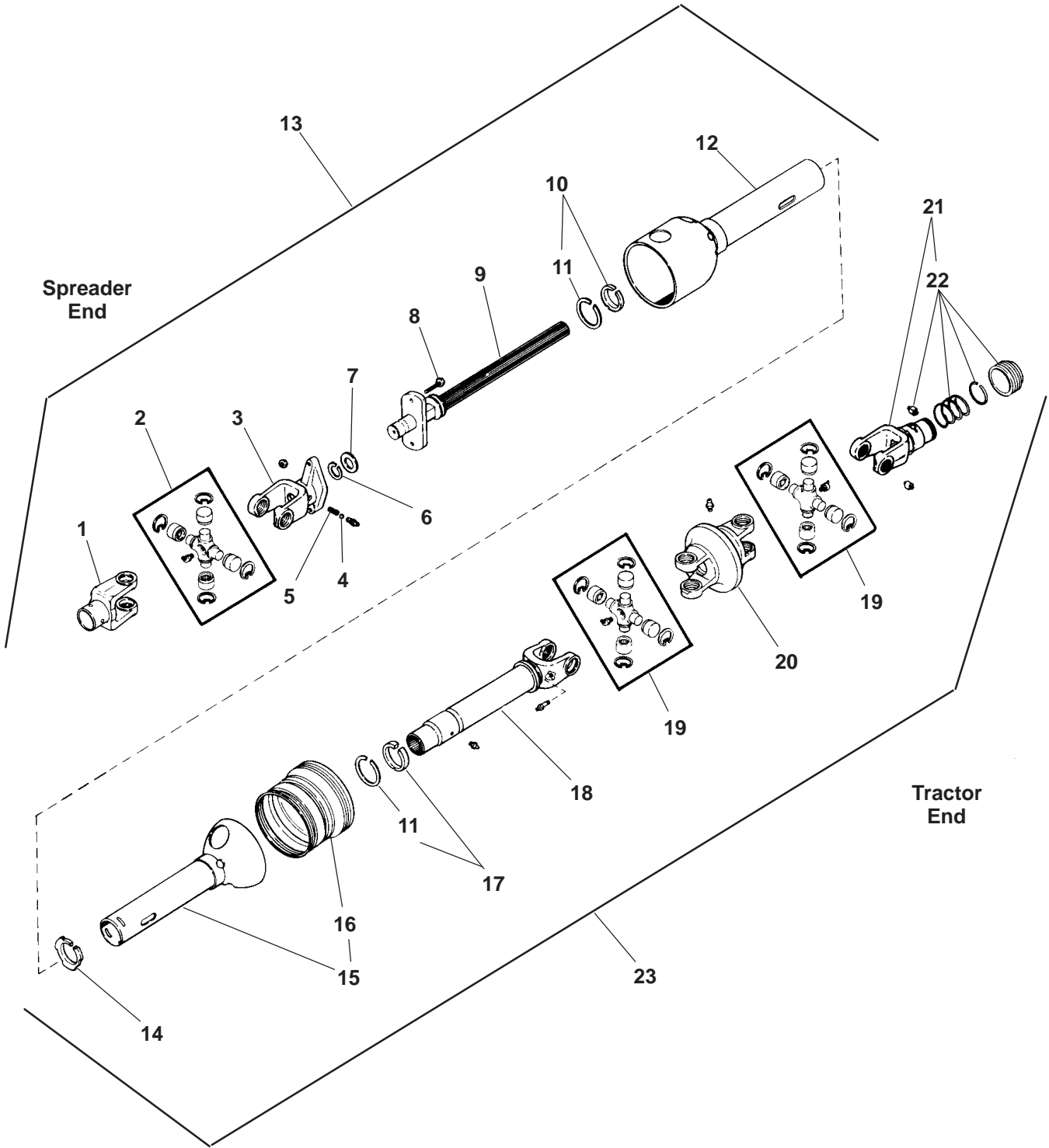

## 329 – UNIVERSAL DRIVES (BEFORE MS329–SN4525 & HD329–SN8612)

Ref. No.	Part No.	Description	Qty. Req.	Ref. No.	Part No.	Description	Qty. Req.
01	084245	YOKE .....	1	14	084242	BEARING/CENTRALIZER .....	1
	650906	SQHSS 3/8X1 (JN) .....	2	15	084237	SHIELD/TRACTOR HALF .....	1
02	045327	KIT/CROSS .....	1			(INCL REF. 16)	
	570009	FITTING/GREASE .....	1	16	088818	GUARD/PLASTIC .....	1
03	054117	YOKE/SHEAR (540 RPM) .....	1	17	095132	KIT/REPAIR (INCL REF. 11) .....	1
	084250	YOKE/SHEAR (1000 RPM) .....	1	18	084238	TUBE W/JOINT ASSY .....	1
	570002	FITTING/GREASE .....	1		570001	FITTING/GREASE (LONG) .....	1
04	125874	BALL/STEEL5/16 .....	1		570002	FITTING/GREASE .....	1
05	045884	SPRING/COMPRESSION .....	1	19	084241	KIT/CROSS .....	2
06	045882	RING/RETAINING .....	1		570009	FITTING/GREASE .....	2
07	045883	WASHER .....	1	20	084239	HOUSING/CENTER ASSY .....	1
08	062372 <sub>a</sub>	BOLT/SHEAR 5/16X2 GR 5 .....	1		570014	FITTING/GREASE .....	1
		(540 RPM)		21	084240	JOINT W/SLIDE LOCK ASSY .....	1
		(1) 5/16LN				(540 RPM)	
	080452 <sub>b</sub>	BOLT/SHEAR 1/4X2 GR 5 FOR .....	1			(INCL REF. 22)	
		(1000 RPM)			084248	YOKE/SLIDE LOCK ASSY .....	1
		(1) 1/4LN				(1000 RPM)	
09	084244	SHAFT/PTO W/SHEAR FLANGE .....	1			(INCL REF. 22)	
		(540 RPM)		22	095166	KIT/SLIDE LOCK .....	1
	084249	SHAFT/PTO W/SHEAR FLANGE .....	1	23	084235	PTO/TRACTOR HALF ASMD .....	1
		(1000 RPM)				(540 RPM)	
10	095130	KIT/REPAIR (INCL REF. 11) .....	1		084246	PTO/TRACTOR HALF ASMD .....	1
11	510100	RETAINER/BEARING .....	2			(1000 RPM)	
12	084243	GUARD/OUTER .....	1				
13	084236 <sub>c</sub>	PTO/MACHINE HALF ASMD .....	1				
		(540 RPM)					
	084247 <sub>d</sub>	PTO/MACHINE HALF ASMD .....	1				
		(1000 RPM)					

- a) For replacement Shear Bolts, order Kit 901605 which contains eight each 062372 Bolt and 071703 Lock Nut.
- b) For replacement Shear Bolts, order Kit 080453 which contains eight each 080452 Bolt and 071700 Lock Nut.
- c) No longer available. For replacement, order 112764.
- d) No longer available. For replacement, order 112753.

# 329 – COMPONENTS – AUGER & JACK

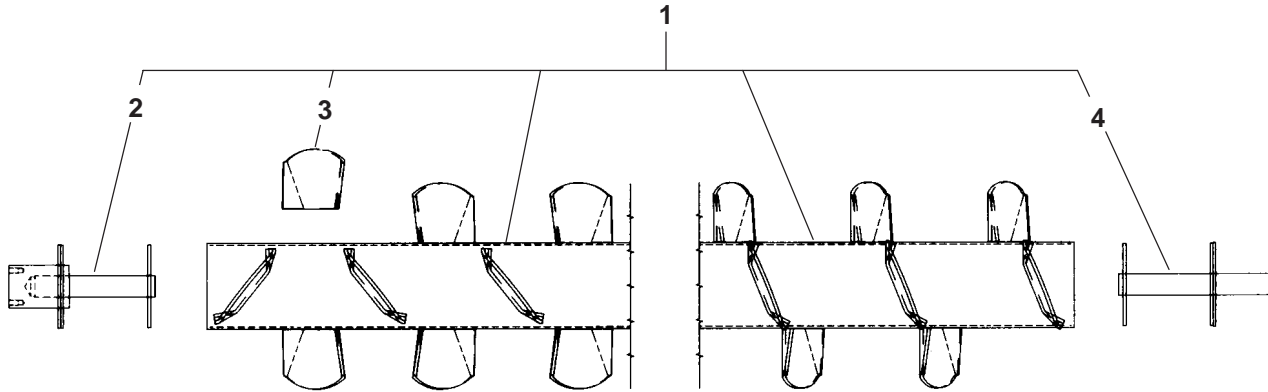

Ref. No.	Part No.	Description	Qty. Req.	Ref. No.	Part No.	Description	Qty. Req.
01	080286	AUGER/ASSEMBLY .....	1	03	080291	FLIGHT/FORMED .....	5
02	080220	SHAFT/FRONT ASSY (WELD-ON) .....	1	04	080226	SHAFT/REAR ASSY (WELD-ON) .....	1

## 082027 Jack Components

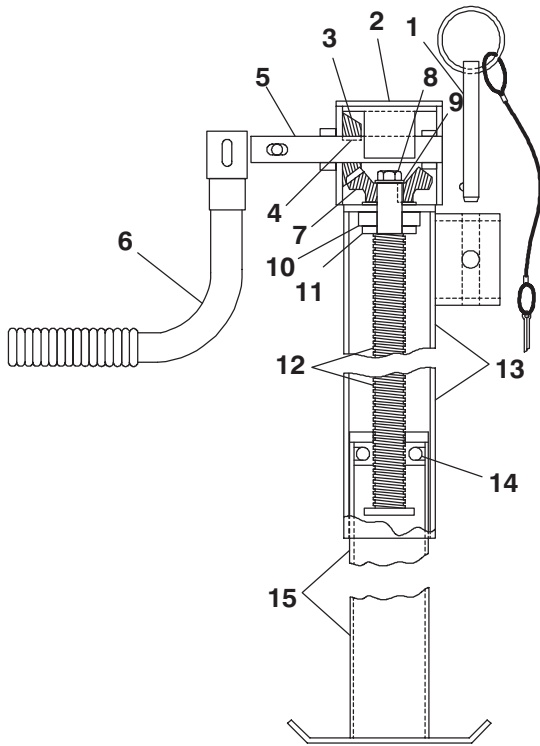

Ref. No.	Part No.	Description	Qty. Req.
00	082027	JACK/ASSY .....	1
		CONSISTS OF:	
01	082650	PIN/BALL LOCK ASSY .....	1
02	082649	CAP/POLY .....	1
03	082660	GEAR/12T .....	1
04	082645	KEY/SQUARE 1/2X3/4 .....	2
05	082659	SHAFT/PINION .....	1
06	082647	CRANK/ASSY W/GRIP .....	1
07	082658	GEAR/18T .....	1
08	082657	SCREW/LOCK CAP .....	1
09	082656	WASHER/GEAR RETAINER .....	1
10	082644	WASHER/SPACER .....	1
11	082655	BEARING/THRUST .....	1
12	082654	SCREW/LH ACME ASSY .....	1
13	082653	TUBE/OUTER .....	1
14	082652	PIN/RETAINING 3/8 NUT .....	2
15	082651	TUBE/INNER .....	1

# 329 – COMPONENTS – HYDRAULIC CYLINDERS

## 095145 & 095146 Hydraulic Cylinders

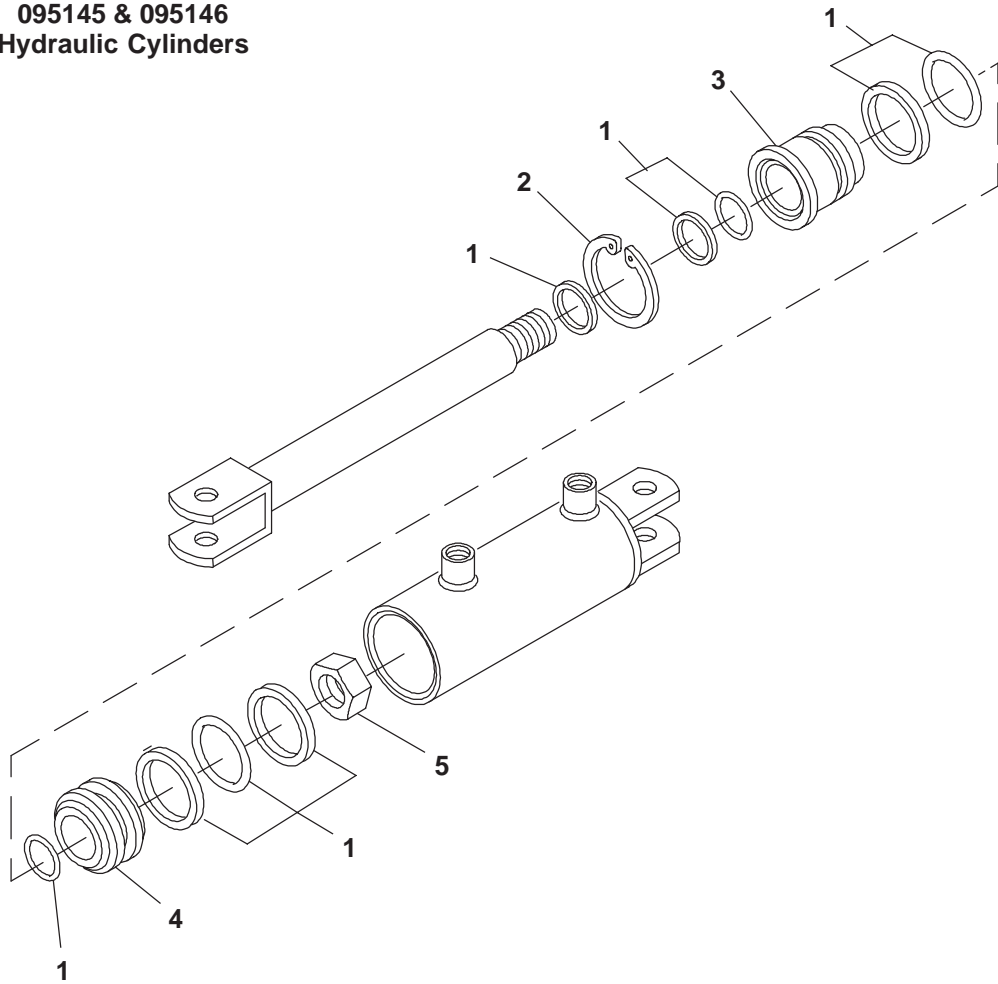

Ref. No.	Part No.	Description	Qty. Req.	Ref. No.	Part No.	Description	Qty. Req.
00	095145	CYLINDER/HYDRAULIC .....	1	02	089689	RING/HYD. CYL. SNAP .....	1
		OR		03	089691	HEAD .....	1
00	095146	CYLINDER/HYDRAULIC .....	1	04	089690	PISTON .....	1
		CONSISTS OF:		05	073788	NUT .....	1
01	089693	KIT/HYD. CYL. REPAIR .....	1				

803065 Hydraulic Assist Brakes  
(Factory Installed)

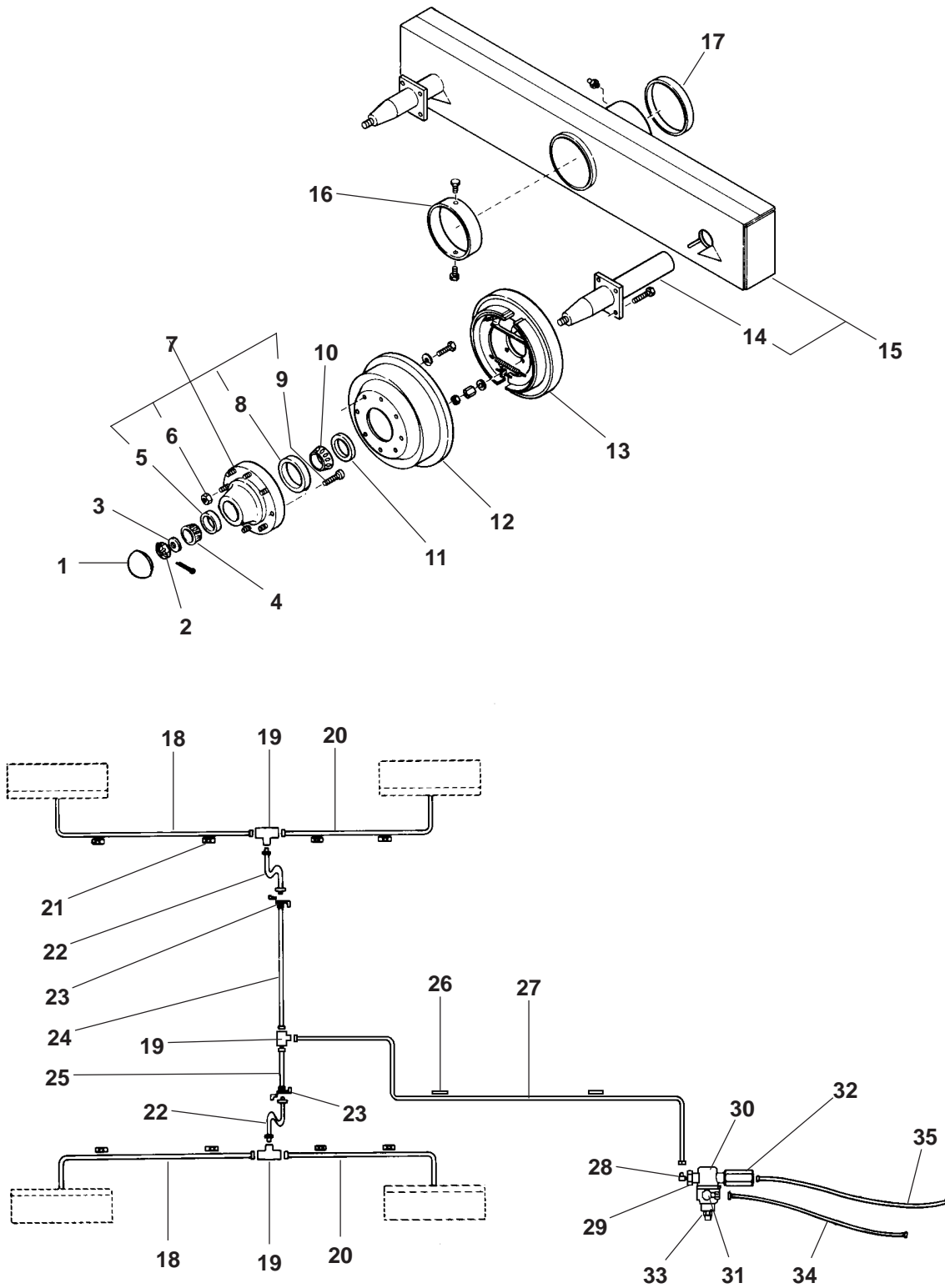

## 329 – ACCESSORIES – HYDRAULIC BRAKES

Ref. No.	Part No.	Description	Qty. Req.	Ref. No.	Part No.	Description	Qty. Req.
00	803065	BRAKES/HYDRAULIC ASSIST	1	20	606171	LINE ASSY/BRAKE 27IN	2
		CONSISTS OF:		21	606130	CLAMP/BRAKE LINE	8
01	003938	CAP/GREASE	4		075274	RIVET/BLIND 3/16IN	8
02	650933	NUT/SLOTTED 1–12NF	4	22	606129	HOSE/BRAKE LINE	2
	655024	PIN/COTTER 3/16x2	4	23	606124	CLIP/BRAKE HOSE	2
03	003943	WASHER	4	24	606173	LINE ASSY/BRAKE 36IN	1
04	042163	CONE/BEARING–OUTER	4	25	606170	LINE ASSY/BRAKE 12IN	1
05	042162	CUP/BEARING–OUTER	4	26	606125	CLIP/BRAKE LINE	2
06	079152	NUT/WHEEL 5/8–18UNF	32	27	606174	LINE ASSY/BRAKE 84IN	1
07	097415	HUB/ASSY	4	28	606119	ELBOW/90 DEG	1
		(INCL REF. 05, 06, 08 & 09)		29	660044	BUSHING/HEX RED 1/2X1/8	1
08	004375	CUP/BEARING–INNER	4	30	607185	U–CLAMP 5/16X3X2	1
09	078657	BOLT/STUD WHEEL	32	31	580052	ADAPTOR/90 DEG 1/2X3/8	1
10	003940	CONE/BEARING–INNER	4	32	098369	VALVE/RESTRICTOR	1
11	083109	SEAL/GREASE	4	33	606118	VALVE/RELIEF	1
12	606113	DRUM/BRAKE 13IN DIA	4	34	606112	HOSE/ASSY 3/8X132IN	1
	651011	CS 1/2NFX1 GR8 (L)	32	35	607186	HOSE/ASSY 1/4X132IN	1
13	606128 <sup>a,b</sup>	BRAKE/ASSY LH	2				
	650654	CS 1/2NFX2 GR8 (NF–N, L)	8				
	606127 <sup>a,b</sup>	BRAKE/ASSY RH (NOT SHOWN)	2				
	650654	CS 1/2NFX2 GR8 (NF–N, L)	8				
14	606256 <sup>d</sup>	SPINDLE (WELD–ON)	4				
15	607187	AXLE/TANDEM ASSY (INCL REF. 14)	2				
	570002	FITTING/GREASE 1/8 STR	4				
16	606730	TUBE/RETAINER	2				
	650882	CS 1/2X8	2				
17	606142	TUBE/SPACER	2				
18	606172	LINE ASSY/BRAKE 35IN	2				
19	606123	TEE/BRAKE LINE 3/8–24 FEM	3				

- a)** For Brake Lining Repair Kit, order 113247.
- b)** For Wheel Cylinder Repair Kit, order 112208.
- c)** For Brake Springs and Adjustment Screw, procure equivalent parts locally as shown in chart below.
- d)** For replacement WELD–ON Brake Mounting Flange, order 606157. For replacement Gussets, order 081398 (2 required per Spindle).

ITEM	DICO PART NUMBER
Front Lever Spring (RED)	9785
Rear Shoe Spring (ORANGE)	9786
Adjustment Screw (YELLOW)	9784
Brake Assembly (Reference)	17196

804683 Hydraulic Lid Kit

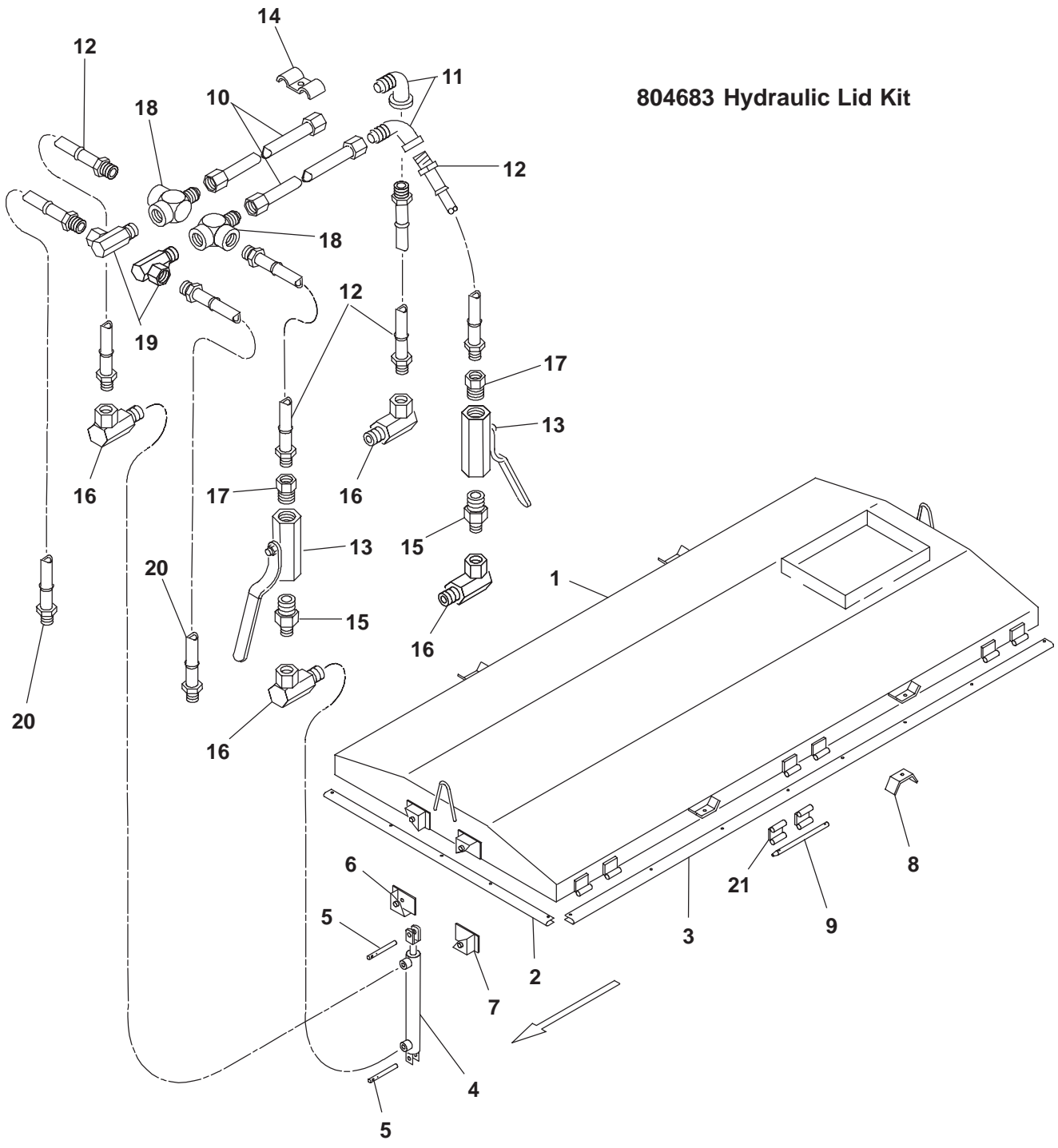

## 329 – ACCESSORIES – HYDRAULIC LID

Ref. No.	Part No.	Description	Qty. Req.	Ref. No.	Part No.	Description	Qty. Req.
01	092816	LID/TANK ASSY .....	1	10	092805	TUBE/HYDRAULIC W/NUTS .....	2
02	092824	SEAL/LID END .....	2	11	064673	ELBOW/FEMALE .....	2
	651069	BOLT/ELEVATOR 5/16X1-1/4 (N, L) ...	16	12	083231	HOSE/ASSY .....	4
03	092809	SEAL/LID SIDE .....	2	13	092813	VALVE .....	2
	651069	BOLT/ELEVATOR 5/16X1-1/4 (N, L) .	32	14	018453	CLAMP/HOSE .....	3
04	095146 <sub>a</sub>	CYLINDER/HYDRAULIC 2X8 .....	2		070856	3/8 FLN .....	3
		(USED AFTER <del>MS329-SN4575</del> USED AFTER <b>HD329-SN8630</b> )		15	072901	NIPPLE/MALE 3/8 TO 1/2 .....	2
	606086 <sub>b</sub>	CYLINDER/HYDRAULIC 2X18 .....	2	16	077969	ELBOW/HYD. FITTING 90 DEG. ....	4
		(USED BEFORE <del>MS329-SN4576</del> USED BEFORE <b>HD329-SN8631</b> )			042618	UNION/90 DEG. SWIVEL ADAPTER ....	4
05	092812	PIN/CYLINDER PIVOT .....	4			(USED BEFORE <del>MS329-SN4576</del> USED BEFORE <b>HD329-SN8631</b> )	
	074090	PIN/SPRING .....	4	17	057655	REDUCER/STEEL PIPE 1/2NPT .....	2
06	092593	BRACKET/CYL. PIVOT LT .....	2	18	092806	FITTING/HYDRAULIC .....	2
07	092804	BRACKET/CYL. PIVOT RT .....	2	19	580052	ELBOW/90 DEG. SWIVEL ADAPTER ...	2
08	092803	BRACKET/HOLD DOWN .....	4	20	083250	HOSE/ASSY .....	2
	650526	CS 3/4X6 (NILN) .....	4	21	092814	HINGE/LID ASSY LOWER .....	12
09	092810	PIN/HINGE .....	6				
	655020	PIN/COTTER 3/16X1-1/2 .....	12				
	092811	PIN/DRIVE .....	1				
	655020	PIN/COTTER 3/16X1-1/2 .....	2				

**a)** For repair parts, see page titled COMPONENTS, HYDRAULIC CYLINDERS.

**b)** For repair, order 090033 Seal Kit.

# 329 – ACCESSORIES – SPLASH GUARDS, SIDE RAILS & SAFETY CHAIN

## 803325 Spash Guards w/Side Rails

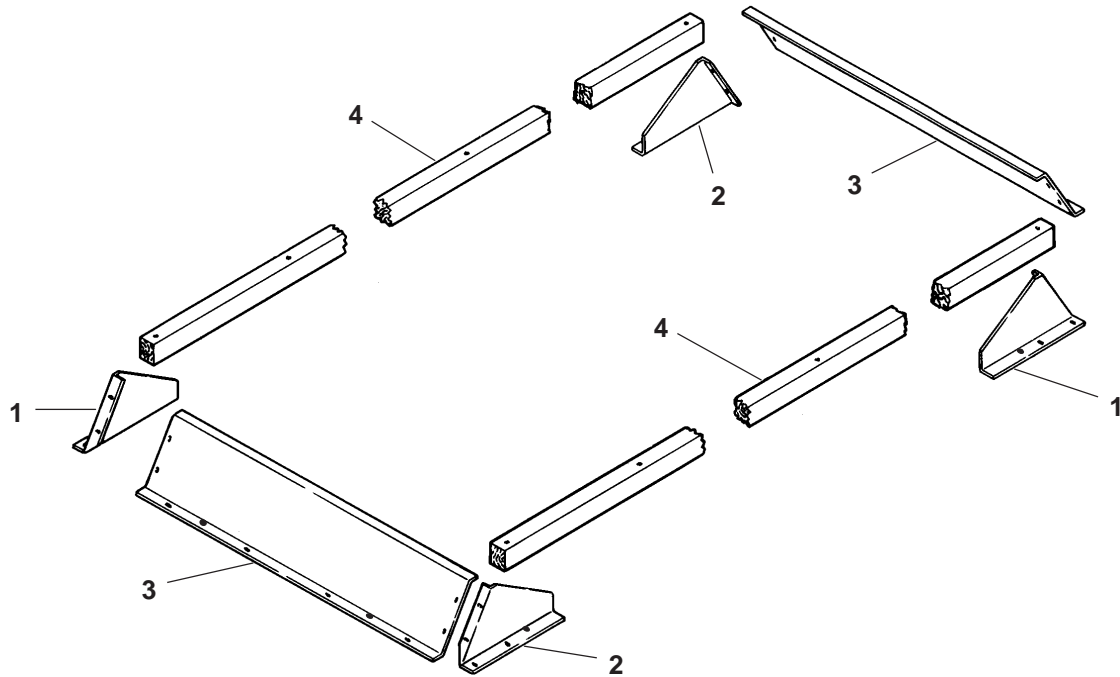

Ref. No.	Part No.	Description	Qty. Req.	Ref. No.	Part No.	Description	Qty. Req.
00	803325	GUARD/SPLASH W/SIDE RAILS	1	03	080884	SHIELD	2
		CONSISTS OF:			650490	CS 3/8X1 (N, L, P)	12
01	080110	SHIELD/SPLASH (RT FRONT OR LT REAR)	2	04	112137	RAIL 2-1/2SQ X 174	2
	650490	CS 3/8X1 (N, L, 16P)	10		650458	CB 3/8X4-1/2 (N, P, L)	8
02	080111	SHIELD/SPLASH LT FRT (LT FRONT OR RT REAR)	2				
	650490	CS 3/8X1 (N, L, 16P)	10				

## 803099 Safety Chain

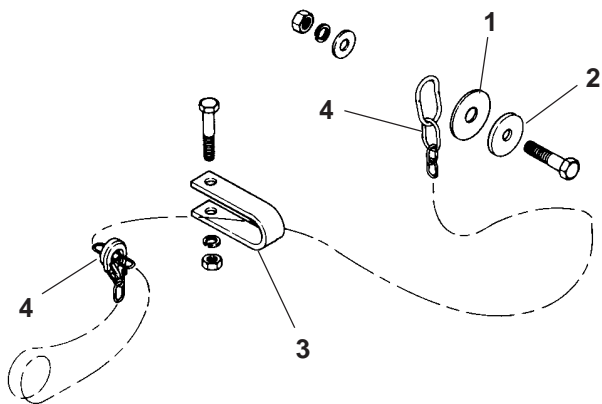

Ref. No.	Part No.	Description	Qty. Req.
00	803099	CHAIN/SAFETY 30,000 LB	1
		CONSISTS OF:	
01	043912	WASHER	1
02	069076	WASHER	1
	651072	CS 3/4X3-1/4 (N, L, P)	1
03	080894	CLEVIS	1
	650695	CS 5/8X3-1/2 (N, L)	1
04	080895	CHAIN/SAFETY ASSY	1

## 329 - NUMERICAL INDEX

Part No.	Page No.	Ref. No.	Part No.	Page No.	Ref. No.	Part No.	Page No.	Ref. No.	Part No.	Page No.	Ref. No.
H 8352A	05	18	070856	25	14	080884	26	03	083229	08	05
R13216	07	07	072901	25	15	080894	26	03	083230	12	08
S 16174	05	16	073788	21	05	080895	26	04	083231	12	09
S 16174	07	22	074090	25	05	081087	13	04	083231	25	12
003938	14	04	075274	13	07	081398	23	14	083232	11	06
003938	23	01	075274	23	21	081424	12	13	083232	12	06
003940	23	10	077066	07	05	081500	05	07	083250	12	03
003943	14	06	077969	25	16	081501	05	09	083250	25	20
003943	23	03	078580	13	09	081742	08	19	083251	12	04
004375	23	08	078657	23	09	081954	13	10	083252	08	12
018453	11	11	079098	11	11	082010	08	03	083253	08	13
018453	12	11	079152	14	01	082011	08	04	083254	08	17
018453	25	14	079152	23	06	082012	13	12	083255	08	15
042162	14	08	080110	26	01	082016	08	10	083256	08	14
042162	23	05	080111	26	02	082020	07	09	083257	05	04
042163	14	07	080220	20	02	082021	07	11	083258	05	11
042163	23	04	080226	20	04	082021	09	13	083259	05	21
042618	25	16	080233	07	15	082022	07	11	083277	07	12
042858	09	06	080286	20	01	082022	09	13	083281	09	05
043912	26	01	080291	20	03	082027	13	11	083282	09	17
045171	07	03	080397	05	01	082027	20	00	083283	09	14
045327	19	02	080452	17	17	082263	05	15	083284	09	15
045581	14	02	080452	19	08	082644	20	10	083285	09	19
045581	15	18	080453	17	17	082645	20	04	083287	09	01
045668	09	21	080453	19	08	082647	20	06	083288	09	03
045857	17	15	080454	07	05	082649	20	02	083289	09	07
045882	19	06	080455	07	05	082650	20	01	083669	07	04
045883	19	07	080595	09	09	082651	20	15	084235	17	01
045884	19	05	080598	07	04	082652	20	14	084235	19	23
054117	19	03	080605	08	08	082652	20	14	084236	19	13
055021	11	05	080615	05	08	082653	20	13	084237	17	10
055021	12	05	080616	05	19	082654	20	12	084237	19	15
056230	07	14	080616	07	23	082655	20	11	084238	17	07
056230	09	02	080617	07	21	082656	20	09	084238	19	18
057557	09	24	080626	08	21	082657	20	08	084239	17	06
057655	25	17	080630	07	17	082658	20	07	084239	19	20
059272	09	08	080631	07	13	082659	20	05	084240	17	03
059566	09	12	080644	05	17	082660	20	03	084240	19	21
062371	17	17	080645	05	03	083105	14	14	084241	17	05
062372	19	08	080645	07	18	083106	14	09	084241	19	19
064673	25	11	080648	13	03	083107	14	10	084242	17	11
066172	05	02	080648	13	03	083108	14	12	084242	19	14
066172	07	19	080674	08	18	083109	14	13	084243	19	12
068642	13	08	080834	05	10	083109	23	11	084244	19	09
068938	11	02	080845	09	22	083226	08	01	084245	19	01
069076	26	02	080846	05	13	083227	08	07	084246	17	01
						083228	08	06	084246	19	23

# 329 - NUMERICAL INDEX

Part No.	Page No.	Ref. No.	Part No.	Page No.	Ref. No.	Part No.	Page No.	Ref. No.	Part No.	Page No.	Ref. No.
084247	19	13	095130	17	13	116786	13	13	606086	25	04
084248	17	03	095130	19	10	116787	13	14	606099	12	07
084248	19	21	095132	17	08	117499	15	17	606112	23	34
084249	19	09	095132	19	17	119257	11	10	606113	23	12
084250	19	03	095145	11	07	119258	11	15	606118	23	33
084253	13	01	095145	21	00	119693	11	13	606119	23	28
084254	13	02	095146	11	01	125874	19	04	606123	23	19
084255	13	05	095146	21	00	141155	05	05	606124	23	23
084256	13	06	095146	25	04	500195	05	14	606125	23	26
087107	11	14	095147	11	03	500195	07	12	606127	23	13
088695	05	12	095148	11	04	510100	17	09	606128	23	13
088749	08	09	095149	11	16	510100	19	11	606129	23	22
088818	17	02	095150	11	08	520013	14	11	606130	23	21
088818	19	16	095151	11	09	520132	07	20	606142	14	17
088904	11	12	095166	17	04	520194	07	08	606142	15	19
089689	21	02	095166	19	22	520195	07	06	606142	23	17
089690	21	04	097307	11	15	570001	17	07	606157	23	14
089691	21	03	097415	23	07	570001	19	18	606170	23	25
089693	21	01	098369	23	32	570002	05	11	606171	23	20
090033	12	01	099242	07	10	570002	07	07	606172	23	18
090033	12	07	110032	13	15	570002	08	07	606173	23	24
090033	25	04	110051	11	13	570002	14	15	606174	23	27
091918	07	09	110448	11	10	570002	15	01	606256	23	14
092593	25	06	112137	26	04	570002	15	02	606308	07	08
092803	25	08	112184	15	05	570002	17	07	606465	07	01
092804	25	07	112185	15	06	570002	17	16	606541	09	04
092805	25	10	112186	15	07	570002	19	03	606542	09	16
092806	25	18	112187	15	08	570002	19	18	606542	09	18
092809	25	03	112188	15	09	570002	23	15	606662	05	14
092810	25	09	112189	15	10	570004	09	10	606663	07	12
092811	25	09	112190	15	11	570005	05	08	606666	05	06
092812	25	05	112191	15	12	570005	05	15	606671	05	20
092813	25	13	112192	15	13	570005	07	21	606671	09	11
092814	25	21	112193	15	14	570005	08	13	606672	09	16
092816	25	01	112195	15	15	570009	17	05	606673	09	18
092824	25	02	112208	23	13	570009	17	15	606676	08	16
094474	07	15	112445	14	03	570009	19	02	606678	09	10
094550	07	16	112446	14	03	570009	19	19	606730	14	16
094796	15	02	112753	17	18	570012	08	15	606730	15	20
094797	15	01	112764	17	18	570014	17	06	606730	23	16
094802	15	03	112771	17	16	570014	17	06	606734	07	07
094803	15	04	112772	17	14	580049	19	20	606941	08	11
094807	08	02	112773	17	12	580052	12	02	607185	23	30
094952	05	05	112774	17	16	580052	23	31	607186	23	35
095026	05	02	113034	07	02	580052	25	19	607187	23	15
095112	14	15	113247	07	02	580058	12	12	650201	05	16
				23	13	606086	12	01	650201	07	11

## 329 - NUMERICAL INDEX

Part No.	Page No.	Ref. No.	Part No.	Page No.	Ref. No.	Part No.	Page No.	Ref. No.	Part No.	Page No.	Ref. No.
650201	07	22	650527	07	15	650933	23	02	655024	23	02
650212	05	09	650545	08	10	650953	13	03	655033	15	16
650307	05	13	650548	13	04	651011	23	12	655046	11	06
650307	09	09	650569	07	07	651029	07	04	655046	12	06
650452	09	10	650585	09	05	651069	08	20	655048	08	01
650458	26	04	650647	13	12	651069	25	02	655048	08	11
650481	15	15	650654	23	13	651069	25	03	660004	09	23
650490	13	13	650654	23	13	651072	26	02	660009	12	10
650490	13	15	650692	11	11	651090	05	01	660044	09	20
650490	26	01	650695	26	03	651187	08	16	660044	23	29
650490	26	02	650731	05	21	651292	07	09	660079	12	14
650490	26	03	650815	13	03	655006	13	01	803065	23	00
650491	09	19	650882	14	16	655020	05	04	803099	26	00
650494	07	13	650882	23	16	655020	05	19	803325	26	00
650495	07	15	650896	08	09	655020	07	23	900084	07	05
650495	09	25	650906	17	16	655020	25	09	901605	19	08
650502	15	20	650906	19	01	655022	14	14	901606	17	17
650526	25	08	650933	14	05						

# Index

## A

Accessories  
Brakes, 22  
Hydraulic lid, 24  
Safety chain, 26  
Side rails, 26  
Splash guards, 26  
Auger  
Assembly, 20  
Drive, 4  
Slides & mounting, 8  
Axle, tandem  
HD329, 15  
MS329, 14

## B

Brakes, hydraulic, 22

## C

Chains & sprockets, 4  
Expeller drive, 6  
Components  
Auger, 20  
Hydraulic cylinders, 21  
Jack, 20  
Cylinder, Components, 21  
Cylinders, 10, 12  
Hydraulic lid, 24

## D

Decal  
Application, 2  
Locations, 2-3  
Drive  
Auger, 4  
Expeller, 6  
Drive shields, 13

## E

Expeller  
Assembly, 6  
Drive, 6  
Pan, 8

## G

Gate, discharge, 8  
Gearbox, 9  
Guards, drive, 13

## H

Hitch, 13  
Hitchjack. *See* Jack  
Hub, wheel  
HD329, 15  
MS329, 14  
Hydraulic brakes accessory, 22  
Hydraulic components, 10, 12  
Hydraulic cylinder, Components, 21

## J

Jack  
Assembly, 13  
Components, 20

## L

Lid, hydraulic, 24  
Liners, 8

## P

Paint Notice, 2  
Pan, expeller, 8  
PTO, 16, 18

## S

Spindles  
HD329, 15  
MS329, 14  
Sprockets & chains, 4  
Expeller drive, 6

## T

Tandem axle  
HD329, 15  
MS329, 14  
Telescoping PTO, 16, 18  
Torque Specification Chart, 31

## U

U-joints, 16, 18  
Universal Drive (PTO), 16, 18



## W

Wheels  
HD329, 15  
MS329, 14

# TORQUE SPECIFICATIONS

**NOTE:** Use these torque values when tightening **GEHL** hardware (excluding: Locknuts and Self-tapping, Thread Forming and Sheet Metal Screws) unless specified otherwise.

All torque values are in Lb-Ft except those marked with an \* which are Lb-In  
(For metric torque value Nm, multiply Lb-Ft value by 1.355 or Lb-In value by 0.113)

Unified National Thread	Grade 2 		Grade 5 		Grade 8 	
	Dry	Lubed	Dry	Lubed	Dry	Lubed
8-32	19*	14*	30*	22*	41*	31*
8-36	20*	15*	31*	23*	43*	32*
10-24	27*	21*	43*	32*	60*	45*
10-32	31*	23*	49*	36*	68*	51*
1/4-20	66*	50*	9	75*	12	9
1/4-28	76*	56*	10	86*	14	10
5/16-18	11	9	17	13	25	18
5/16-24	12		19	14		20
3/8-16	20	15	30	23	45	35
3/8-24	23	17	35	25	50	
7/16-14	32	24	50	35	70	55
7/16-20	36	27	55	40	80	60
1/2-13	50	35	75	55	110	80
1/2-20	55	40	90	65	120	90
9/16-12	70	55	110	80	150	110
9/16-18	80	60	120	90	170	130
5/8-11	100	75	150	110	220	170
5/8-18	110	85	180	130	240	180
3/4-10	175	130	260	200	380	280
3/4-16	200	150	300	220	420	320
7/8-9	170	125	430	320	600	460
7/8-14	180	140	470	360	660	500
1-8	250	190	640	480	900	680
1-14	270	210	710	530	1000	740

## Attaching Hardware Table

Size & Description	Part Number	Size & Description	Part Number	Size & Description	Part Number	Size & Description	Part Number
#10 L	650549	3/8 FLN	070856	1/2 FLN	081374	5/8 LN	067823
#10-24 N	650550	3/8 JN	653038	1/2 L	654030	5/8 N	653021
1/4 LN	071401	3/8 L	654026	1/2 LN	071706	5/8 P	654012
5/16 JN	653034	3/8 LN	071403	1/2 N	653018	3/4 L	654034
5/16 L	654024	3/8 N	653010	1/2 NF-N	653019	3/4 LN	064331
5/16 LN	071701	3/8 P	654006	1/2 NILN	068034	3/4 N	653026
5/16 N	653007	7/16 L	654028	1/2 P	654009	3/4 P	654014
5/16 P	654004	7/16 N	653015	5/8 L	654032	1 P	654016

**GEHL**®

**Gehl Company** 143 Water Street, P.O. Box 179, West Bend, WI 53095-0179