

Form No.
904122
Replaces
903751

L22

Manure Loader



OPERATOR'S AND SERVICE PARTS MANUAL

G E H L [®] C O M P A N Y

Warranty

GEHL COMPANY New Agricultural Equipment

GEHL Company (Incorporated), hereinafter referred to as **GEHL**, as manufacturer of quality machinery since 1859, warrants new **GEHL** machinery and/or attachments at the time of delivery to the original purchaser to be free from defects in material and workmanship if properly set up and operated in accordance with the recommendations set forth in **GEHL's** Operator Manual.

GEHL's liability for any defect with respect to accepted goods shall be limited to repairing the goods at an authorized **GEHL** dealer or other **GEHL** designated location, or replacing them, as **GEHL** shall elect. The above shall be in accordance with **GEHL** warranty adjustment policies. **GEHL's** obligation shall terminate twelve (12) months after the delivery of the goods to the original user or when the equipment is first put into use.

This warranty shall not apply to any machine or attachment which shall have been repaired or altered outside the **GEHL** factory or authorized **GEHL** dealership or in any way so as in **GEHL's** judgment, to affect its stability or reliability, nor which has been subject to misuse, negligence or accident, nor to any machine or attachment which shall not have been operated in accordance with **GEHL's** printed instructions or beyond the Company recommended machine rated capacity.

This warranty shall not be limited to items which are subject to the warranties of their respective manufacturers. Such items would include but would not be limited to engines, clutches, universal joints, knives, hydraulic components, bearings, tires, belts and other trade accessories.

EXCLUSION OF WARRANTIES

Except as otherwise expressly stated herein, **GEHL** makes no representation or warranty of any kind, express or implied, AND MAKES NO WARRANTY OF MERCHANTABILITY IN RESPECT TO ITS MACHINERY AND/OR ATTACHMENTS AND MAKES NO WARRANTY THAT ITS MACHINERY AND/OR ATTACHMENTS ARE FIT FOR ANY PARTICULAR PURPOSE. **GEHL** shall not be liable for incidental or consequential damages for any breach of warranty, including but not limited to inconvenience, rental or replacement equipment, loss of profits or other commercial loss. **GEHL** shall not be liable for, and the buyer assumes all liability for, all personal injury and property damage resulting from the handling, possession or use of the goods by the buyer.

No agent, employee or representative of **GEHL** has any authority to bind **GEHL** to any affirmation, representation or warranty concerning its machinery and/or attachments except as specifically set forth herein.

TABLE OF CONTENTS

Chapter	Description	Page
	Warranty	Inside Front Cover
1	Introduction	2
2	Specifications	3
3	Checklists	5-7
4	SAFETY (Including MANDATORY SAFETY SHUTDOWN PROCEDURE)	8-12
5	Controls & Safety Equipment	13-14
6	Operation	15-16
7	Adjustments	17
8	Lubrication	18
9	Service	19
10	Preparing for Field Operation	19
11	Storage	19
12	Optional Features & Accessories	19
13	Set-up & Assembly	20-23
14	Decal Locations	24-25
15	Service Parts & Numerical Index	26-38
	Index	39
	Standard Hardware Torque Data	Inside Back Cover

CHAPTER 1

INTRODUCTION

Your decision to purchase this piece of GEHL equipment was a good one. We are sure that your decision was strongly considered and that you are looking forward to many seasons of work from this machine.

We, as a Company, have invested a great deal of time and effort in developing our lines of agricultural and industrial equipment. The equipment you have purchased is built with a great deal of pride and designed to give you long life, efficient operation, durability and dependability.

This manual was developed specifically for the machine you have purchased. The information, contained within, was prepared for your assistance in preparing, adjusting, maintaining and servicing your machine. More importantly, this manual provides an operating plan for safe and proper use of your machine. Major points of safe operation are detailed in the **SAFETY** chapter of this manual. Refer to the Table of Contents for an outline (by chapters) of this manual. Use the Index, in the back of the manual, for specific chapter and topic/page number references.

Modern machinery has become more sophisticated and with that in mind, GEHL® Company asks that you read and understand the contents of this manual COMPLETELY and become familiar with your new machine, BEFORE you attempt to operate it. Furthermore, we recommend if this machine is re-sold that this Manual accompany it.

Our wide Dealership network stands by to provide you with any assistance you may require, including genuine GEHL service parts. All parts should be obtained from or ordered through your GEHL Dealer. Give complete information about the part as well as the model number and the serial number of your machine. Record numbers, in space provided, as a handy record for quick reference.

Typical Model & Serial No. Plate

MODEL NO.
L22
SERIAL NO.
(Fill In)
GEHL COMPANY
WEST BEND, WIS. 53095 U.S.A.

The Manure Loader model and serial numbers are on a plate located on the rear wall of the Scoop assembly.

“Right” and “Left” are determined from a position standing behind the Scoop. From this position, the Loading Auger is to the right and the large Scoop Drive Sprocket is on the left.

GEHL Company reserves the right to make changes or improvements in the design or construction of any part without incurring the obligation to install such changes on any unit previously delivered.

Standard hardware torques appear in a chart at the end of the manual.

Throughout this manual, information is provided which is set in **bold type** and introduced by the word **NOTE. BE SURE** to **read carefully** and **comply with** the message or directive given. Following this information will improve your operating or maintenance efficiency, help you to avoid costly breakdown or unnecessary damage and, extend your machine's life.

The GEHL Company, and the American Society of Agricultural Engineers, have adopted this SAFETY ALERT SYMBOL



to pinpoint characteristics which, if not properly followed, can create a safety hazard. When you see this symbol in this manual or on the unit itself, you are reminded to BE ALERT! Your Safety is involved.

CHAPTER 2

SPECIFICATIONS

Model & Description L22 Liquid and Self-leveling
Manure Loader
Power . . . PTO Driven by 540 RPM Tractor with Minimum
PTO Horsepower of 60 hp (45 kw) and
Sufficient Size to Support Loader
Loading Auger Working Height 78 to 114"
(1980 to 2895 mm)
Overall Length 24 ft (7.3 meters)
Overall Scoop Width 105" (2665 mm)
Overall Scoop Height 42" (1065 mm)
Approximate Weight 3330 lb (1510 kg)
Scoop Auger Speed 89 RPM
Loading Auger Speed 356 RPM

Standard Features:

Loading Auger Tube Constructed of 10 Gauge Steel with 12"
(305 mm) Diameter Auger with 3" (76 mm) Diameter Shaft
and 1/4" (6mm) x 4-1/2" (115 mm) Flighting
Scoop Constructed of 10 Gauge Steel with 28" (710 mm)
Diameter Auger
Two Gearbox Primary Drive and #80 Chain-type Final Drive
Shear Bolt Overload Protection for Loading Auger, Infeed
Scoop and PTO Shaft
Hydraulically-controlled Discharge Height Adjustment



WARNING: This Manure Loader is designed and intended **ONLY** for handling **MANURE!** Uses for anything other than manure renders the Warranty null and void.

INTENTIONALLY BLANK

CHAPTER 3

CHECKLISTS

PRE-DELIVERY

After the Manure Loader has been completely set-up, the following inspections should be made before delivering it to the Customer. Check off each item after prescribed action is taken.

Check that:

- NO** parts of unit have been damaged in shipment. Check for such things as dents and loose or missing parts; correct or replace components as required.
- All bolts and fasteners are in place and tightly secured.
- Cylinder, Hoses and Fittings are **NOT** damaged, leaking or loosely connected.
- All Grease Fittings have been properly lubricated, Chains oiled and Gearboxes are filled to their proper levels; see Lubrication chapter of this manual.
- All Guards, Shields and Decals are in place and securely attached.
- Serial Number for this unit is recorded in space provided on this page and page 2.

Hook the unit up to a 540 RPM tractor and test-run it while checking that proper operation is exhibited by all components.

Check that:

- All Rotating PTO Drive Line Shields turn freely.
- All Drives, Chains and Mechanisms are operating smoothly and properly adjusted.

I acknowledge that pre-delivery procedures were performed on this unit as outlined above.

Dealership Name

Dealer Representative's Name

Date Checklist Filled-out

Serial Number

DELIVERY

The following Checklist is an important reminder of valuable information that **MUST** be passed on to the Customer at the time the unit is delivered. Check off each item as you explain it to the Customer.

- Give the Customer his Operator's Manual. Instruct him to be sure to read and completely understand its contents **BEFORE** operating unit.
- Direct him on how to use the Index of this manual as a quick page number locating guide.
- Explain and review with him the SAFETY chapter of this manual.
- Explain and review with him the Controls & Safety Equipment chapter of this manual.
- Explain that regular lubrication is required for continued proper operation and long life. Review with him the Lubrication chapter of this manual.
- Explain and review with him the Service chapter of this manual.
- Completely fill out the Owner's Registration, including Customer's signature and, return it to the Company.

I acknowledge that above points were reviewed with me at the time of delivery.

Customer's Signature

Date Delivered

(Dealer's File Copy)

(Remove Dealer's File Copy At Perforation)

INTENTIONALLY BLANK
(To be removed as Dealer's File Copy)

CHAPTER 3

CHECKLISTS

PRE-DELIVERY

After the Manure Loader has been completely set-up, the following inspections should be made before delivering it to the Customer. Check off each item after prescribed action is taken.

Check that:

- ___ **NO** parts of unit have been damaged in shipment. Check for such things as dents and loose or missing parts; correct or replace components as required.
- ___ All bolts and fasteners are in place and tightly secured.
- ___ Cylinder, Hoses and Fittings are **NOT** damaged, leaking or loosely connected.
- ___ All Grease Fittings have been properly lubricated, Chains oiled and Gearboxes are filled to their proper levels; see Lubrication chapter of this manual.
- ___ All Guards, Shields and Decals are in place and securely attached.
- ___ Serial Number for this unit is recorded in space provided on this page and page 2.

Hook the unit up to a 540 RPM tractor and test-run it while checking that proper operation is exhibited by all components.

Check that:

- ___ All Rotating PTO Drive Line Shields turn freely.
- ___ All Drives, Chains and Mechanisms are operating smoothly and properly adjusted.

I acknowledge that pre-delivery procedures were performed on this unit as outlined above.

Dealership Name

Dealer Representative's Name

Date Checklist Filled-out

Serial Number

DELIVERY

The following Checklist is an important reminder of valuable information that **MUST** be passed on to the Customer at the time the unit is delivered. Check off each item as you explain it to the Customer.

- ___ Give the Customer his Operator's Manual. Instruct him to be sure to read and completely understand its contents **BEFORE** operating unit.
- ___ Direct him on how to use the Index of this manual as a quick page number locating guide.
- ___ Explain and review with him the SAFETY chapter of this manual.
- ___ Explain and review with him the Controls & Safety Equipment chapter of this manual.
- ___ Explain that regular lubrication is required for continued proper operation and long life. Review with him the Lubrication chapter of this manual.
- ___ Explain and review with him the Service chapter of this manual.
- ___ Completely fill out the Owner's Registration, including Customer's signature and, return it to the Company.

I acknowledge that above points were reviewed with me at the time of delivery.

Customer's Signature

Date Delivered

(Pages 5 and 6 Have Been Removed At Perforation)



CHAPTER 4

SAFETY

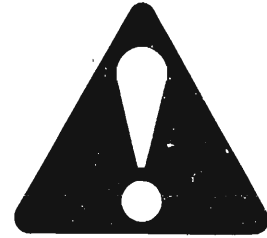

The above Safety Alert Symbol means **ATTENTION! BECOME ALERT! YOUR SAFETY IS INVOLVED!** It stresses an attitude of "Heads Up for Safety" and can be found throughout this Operator's Manual and on the machine itself.

BEFORE YOU ATTEMPT TO OPERATE THIS EQUIPMENT, READ AND STUDY THE FOLLOWING SAFETY INFORMATION. IN ADDITION, MAKE SURE THAT EVERY INDIVIDUAL WHO OPERATES OR WORKS WITH THIS EQUIPMENT, WHETHER FAMILY MEMBER OR EMPLOYEE, IS FAMILIAR WITH THESE SAFETY PRECAUTIONS.

Our Company **ALWAYS** takes the operator and his/her safety into consideration when designing its machinery and guards exposed moving parts for his/her protection. However, some areas can **NOT** be guarded or shielded in order to assure proper operation. In addition, this Operator's Manual and Decals, on the machine, warn of further danger and should be read and observed closely.



DANGER

"DANGER" indicates an imminently hazardous situation which, if not avoided, will result in death or serious injury.



WARNING

"WARNING" indicates a potentially hazardous situation which, if not avoided, could result in death or serious injury.



CAUTION

"CAUTION" indicates a potentially hazardous situation which, if not avoided, may result in minor or moderate injury. May also alert against unsafe practices.

MANDATORY SAFETY SHUTDOWN PROCEDURE

BEFORE unclogging, cleaning, adjusting, lubricating or servicing the unit:

1. Disengage the tractor PTO.
2. Lower Scoop assembly to the ground. Then, unlock and lower Loading Auger Stand and lock it in the "supporting" position. Next, lower Loading Auger until its weight is resting on the Stand.
3. Shut off the tractor engine, place the tractor transmission in park and/or lock brake pedals to prevent any tractor movement
4. Remove the starter switch key and take it with you when leaving the tractor seat
5. Wait for all movement to stop
6. Disconnect the PTO Driveline from the tractor

ONLY when you have taken these precautions can you be sure it is safe to proceed. Failure to follow the above procedure, could lead to death or serious bodily injury.

ADDITIONAL SAFETY REMINDERS

Some photographs, used in this manual, may show Doors, Guards and Shields open or removed for illustration purposes **ONLY**. **BE SURE** that all Doors, Guards and Shields are in their proper operating positions **BEFORE** starting the tractor engine to operate the unit.

Know how to STOP Manure Loader operation **BEFORE** starting it.

Block the Manure Loader so that it will **NOT** fall after it is disconnected from the tractor.

BE SURE that the Storage Stand Mounting Clamp attaching hardware is tightly secured **AT ALL TIMES**.

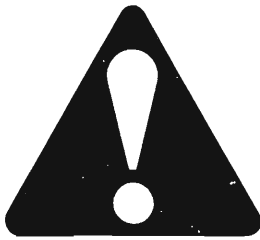

SAFETY

(Continued)

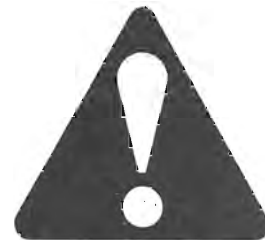

ALWAYS wear safety glasses with side shields when striking metal against metal. It is further recommended that a softer (non-chipable) material be used to cushion the blow. Failure to heed could lead to serious injury to the eye(s) or other parts of the body.

NEVER use your hands to search for hydraulic fluid leaks; use a piece of cardboard. Escaping fluid under pressure can be invisible and can penetrate the skin and cause serious injury! If any fluid is injected into your skin, see a doctor at once! Injected fluid **MUST BE** surgically removed by a doctor familiar with this type of injury or gangrene may result.

Do **NOT** exceed a maximum travel speed of 5 mph (8 kmh) while transporting the Loader.

The PTO Shaft **MUST NEVER** be cut off; instead, adjust the length of the 3-point hitch mounting tubes to obtain the proper Shaft operating length.

Do **NOT** attempt to pick up or raise the Scoop without having both Loader Mount Weldments securely attached to the tractor's 3-point hitch lower links.

The Manure Loader is a 3-point hitch mounted implement which should be frequently inspected to insure that it is correctly and securely attached to the tractor.

ALWAYS lower the Scoop assembly to the ground and support the Loading Auger with the Storage Stand **BEFORE** attempting to clean, adjust, service, lubricate or unplug this machine.



ROTATING DRIVE LINE

DEATH CAN RESULT FROM ENTANGLEMENT
KEEP PEOPLE AND CLOTHING WELL CLEAR

DO NOT OPERATE WITHOUT:

- DRIVE LINE GUARDS
- INPUT SHAFT GUARDS
- TRACTOR MASTER SHIELD
- U-JOINTS LOCKED TO TRACTOR AND IMPLEMENT SHAFTS

08C126

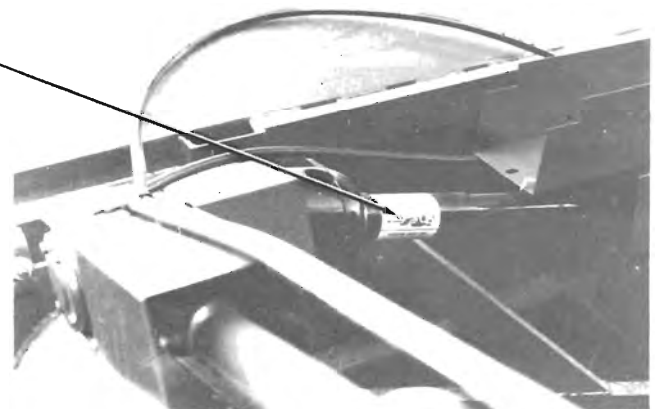
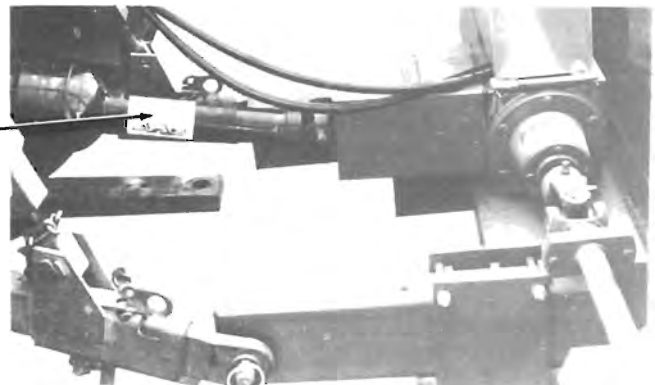



SAFETY

(Continued)



CAUTION

THIS IMPLEMENT IS EQUIPPED TO OPERATE WITH 540 RPM PTO TRACTOR. NEVER ATTEMPT TO CONNECT OR OPERATE WITH 1000 RPM PTO TRACTOR.

073671 REV. 0

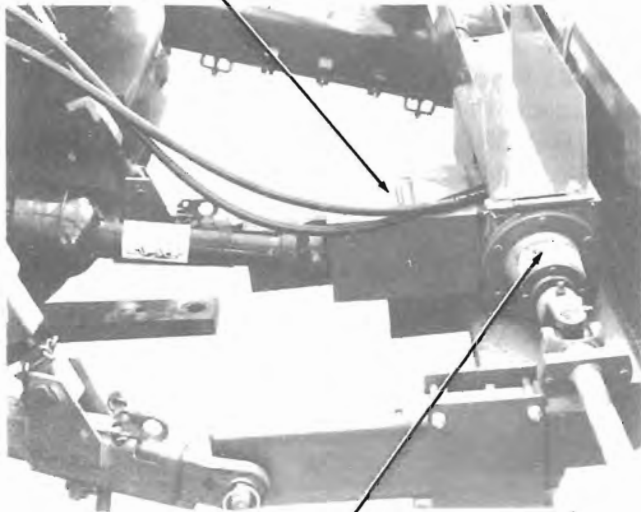

DANGER

KEEP HANDS OUT. DO NOT STEP ON OR CLIMB OVER THE UNIT WHILE MACHINE IS OPERATING. ROTATING AUGER CAN CATCH HANDS OR FEET. FAILURE TO HEED CAN RESULT IN DEATH OR SERIOUS INJURY.

072149

CAUTION

CLOSE OR REPLACE GUARD BEFORE OPERATING MACHINE.

072058

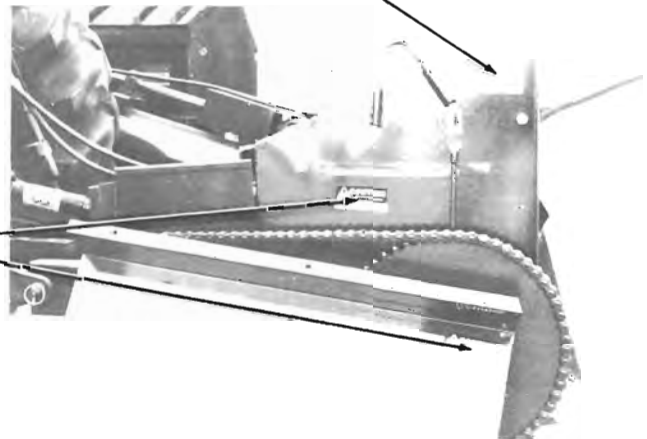

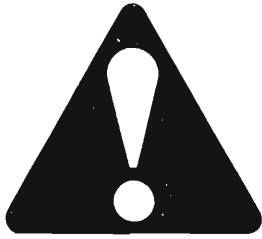

SAFETY

(Continued)

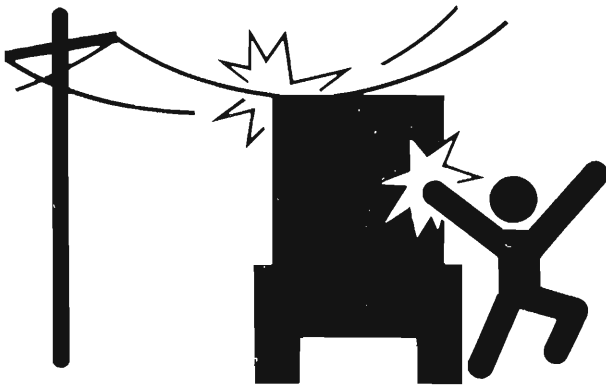

MAINTAIN SAFE CLEARANCE FROM ELECTRIC POWER LINES AND AVOID CONTACT WITH ANY ELECTRICALLY CHARGED CONDUCTOR.

CONTACT WITH ELECTRICAL POWER SOURCE CAN RESULT IN ELECTRICAL SHOCK OR ELECTROCUTION.

FAILURE TO HEED CAN RESULT IN DEATH OR SERIOUS INJURY.

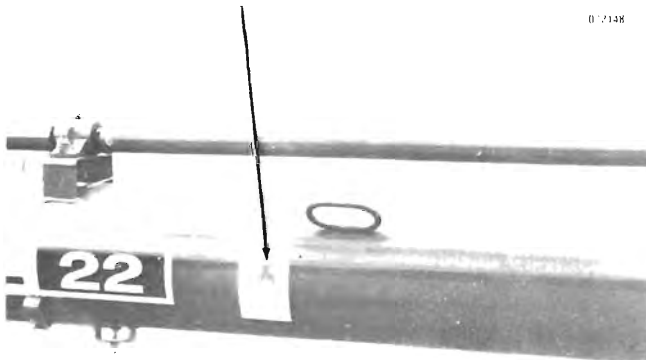

012126



ROTATING DRIVE LINE

DEATH CAN RESULT FROM ENTANGLEMENT
KEEP PEOPLE AND CLOTHING WELL CLEAR

DO NOT OPERATE WITHOUT:

- DRIVE LINE GUARDS
- INPUT SHAFT GUARDS
- TRACTOR MASTER SHIELD
- U-JOINTS LOCKED TO TRACTOR AND IMPLEMENT SHAFTS

FOR YOUR PROTECTION, THIS DRIVE TUBE HAS A GUARD THAT WILL STOP ROTATING WITH CONTACT. BE SURE THIS GUARD CAN TURN FREELY. DO NOT TIE DOWN OR PREVENT ITS ROTATION. DO NOT POUND BELL TO REMOVE DRIVE TUBE.

U-JOINT YOKES MUST BE PROPERLY ATTACHED AND MAINTAINED.

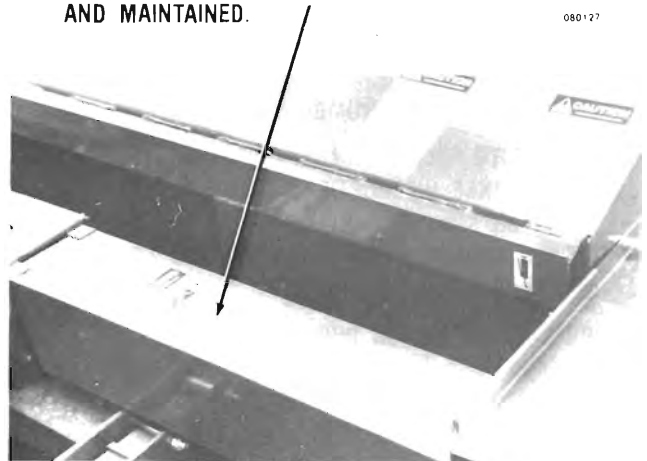

080127



SAFETY

(Continued)

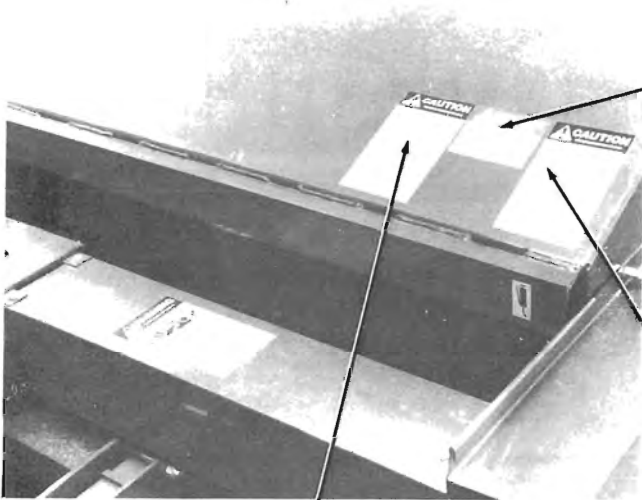

MANURE GAS IS A DEADLY KILLER. GOOD SAFETY PRACTICES DICTATE THAT YOU NEVER ENTER PIT/TANK WHICH CONTAINED MANURE BY YOURSELF. BE SURE SOMEONE ELSE IS AROUND TO HELP YOU OUT IN AN EMERGENCY. BE SURE TO WEAR A SELF-CONTAINED BREATHING APPARATUS IF YOU MUST ENTER THE PIT/TANK.

081145



THE OWNER IS RESPONSIBLE FOR MAKING INFORMATION AVAILABLE ON THE SAFE USE AND PROPER MAINTENANCE OF THIS MACHINE.

DO NOT START, OPERATE OR WORK ON THIS MACHINE UNTIL YOU HAVE CAREFULLY READ AND THOROUGHLY UNDERSTAND THE CONTENTS OF THE OPERATOR'S MANUAL.

IF YOU HAVE ANY QUESTIONS ON OPERATION, ADJUSTMENT OR MAINTENANCE OF THIS MACHINE OR NEED AN OPERATOR'S MANUAL CONTACT YOUR GEHL DEALER OR

GEHL COMPANY, WEST BEND, WISCONSIN 53095
MODEL AND SERIAL NUMBERS WILL BE REQUIRED
FAILURE TO FOLLOW SAFETY, OPERATING AND MAINTENANCE INSTRUCTIONS COULD RESULT IN DEATH OR SERIOUS INJURY TO THE OPERATOR OR BYSTANDERS, POOR OPERATION AND COSTLY BREAKDOWN.

WHEN TRAVELING ON PUBLIC HIGHWAYS OBEY ALL TRAFFIC LAWS CONCERNING LIGHTING, SLOW MOVING VEHICLE SIGNS, ETC. LIMIT SPEED TO 20 MPH AND USE A LOCKING HITCH PIN.

076894



BEFORE UNCLOGGING, CLEANING, ADJUSTING, LUBRICATING OR SERVICING THE UNIT ALWAYS FOLLOW THE MANDATORY SAFETY SHUTDOWN PROCEDURE UNLESS OTHERWISE INSTRUCTED BY THE OPERATOR'S MANUAL. THE PROCEDURE IS:

1. DISENGAGE THE TRACTOR PTO.
2. SHUT OFF TRACTOR ENGINE.
3. WAIT FOR ALL MOVEMENT TO STOP.
4. DISCONNECT THE PTO DRIVELINE FROM THE TRACTOR.

BE SURE PTO SHIELDS TURN FREELY AND KEEP ALL GUARDS AND SHIELDS IN PLACE.

BE SURE MACHINE IS CLEAR OF PEOPLE, TOOLS, AND OTHER OBJECTS BEFORE ENGAGING PTO.

DO NOT WEAR LOOSE OR BAGGY CLOTHING AROUND THIS MACHINE AND KEEP HANDS, FEET AND CLOTHING AWAY FROM MOVING AND POWER DRIVEN PARTS.

KEEP CHILDREN AND SPECTATORS OFF AND AWAY FROM MACHINE WHILE IT IS OPERATING.

KEEP OFF UNIT UNLESS A SPECIFIED OPERATOR'S STATION IS PROVIDED.

077682

CHAPTER 5

CONTROLS & SAFETY EQUIPMENT

This machine is provided with features for operator safety and convenience.

CAUTION: Become familiar with and know how to use ALL safety devices and controls on this machine BEFORE attempting to operate the unit. The Manure Loader is a direct drive machine which runs continuously when the PTO is engaged. Know how to stop machine operation BEFORE starting it.

GUARDS & SHIELDS (Figs. 5-1, 5-2 & 5-3)

CAUTION: BEFORE proceeding to perform any work on the unit and BEFORE removing or opening any Guards or Covers, BE SURE to exercise the MANDATORY SAFETY SHUTDOWN PROCEDURE (page 8). BE SURE to replace ALL Guards and Covers BEFORE resuming operation.

Whenever possible and without affecting machine operation, Guards, Shields and/or hinged Covers have been used on this equipment to protect potentially hazardous areas. In many places, Decals are also provided to warn of potential dangers as well as to display special operating procedures.

LOADING AUGER DRIVE SHAFT (See Fig. 5-2)

The Loading Auger Drive Shaft is equipped with rotating Shields. The Drive Line is protected by Plastic Tubes which fit loosely over the Shaft. The Plastic Tubes should be frequently checked to insure that they are always free to rotate.

WARNING: BE SURE that all Rotating Shields on the Loading Auger Drive Shaft turn freely BEFORE starting the tractor engine.

LOADING AUGER HEIGHT CONTROL (Fig. 5-4 & see Fig. 5-1)

The height of the Discharge end of the Loading Auger is controlled by a hydraulic Cylinder using one of the tractor's remote circuits. The hydraulic hoses should be assembled to the remote valve so that the Auger is raised when the remote control lever is pulled back or up and lowered when the remote control lever is pushed forward or down.

LOADING AUGER STORAGE STAND (Figs. 5-4 & 5-5)

CAUTION: Lower the Scoop assembly to the ground and support the Loading Auger with the Storage Stand BEFORE attempting to clean, adjust, service, lubricate or unplug this machine! BE SURE Storage Stand Mounting Clamp

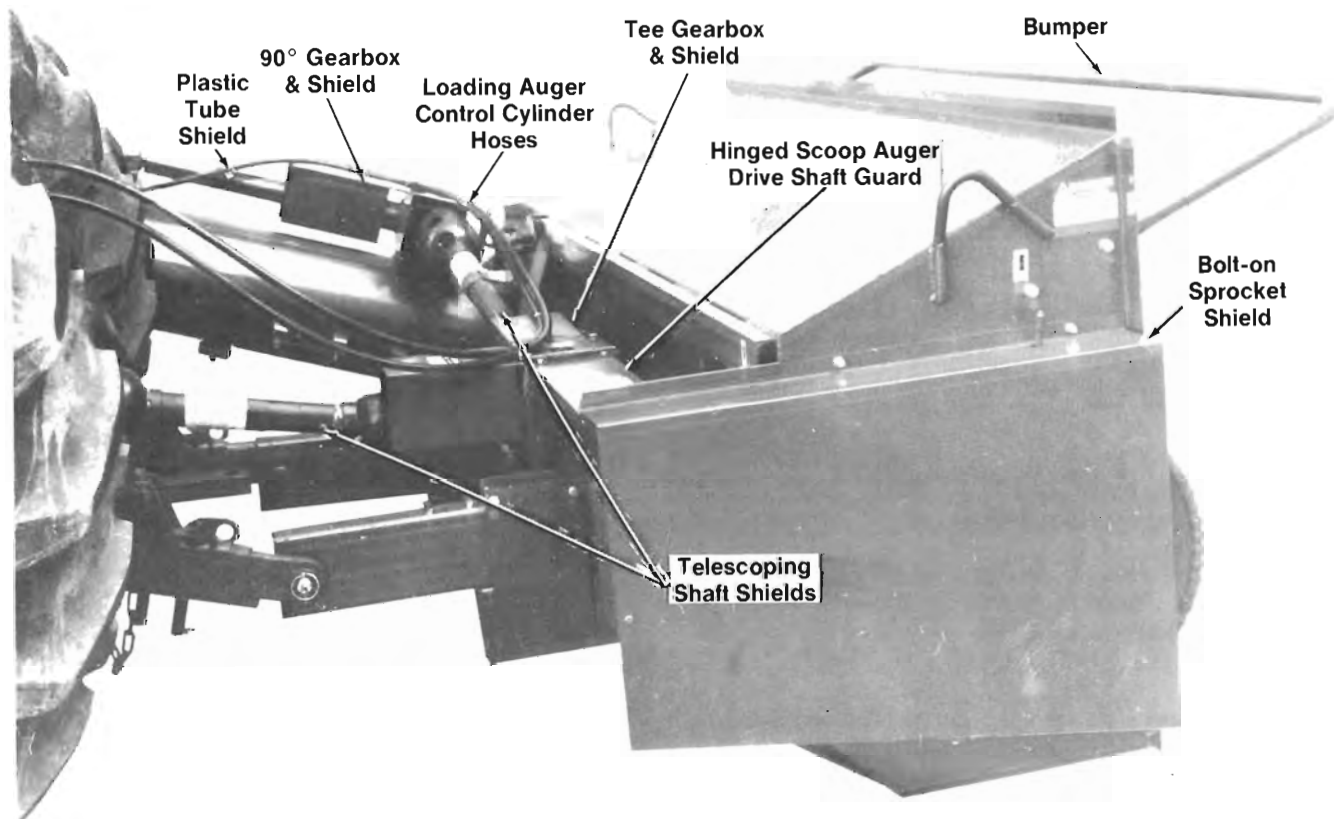

Fig. 5-1

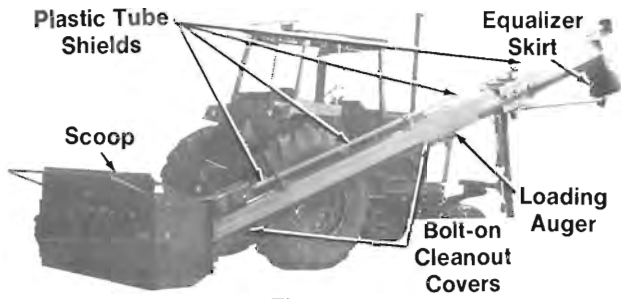

Fig. 5-2

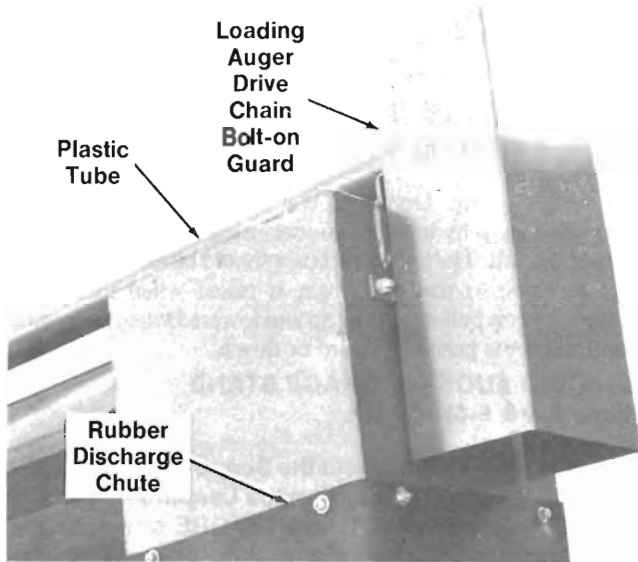

Fig. 5-3

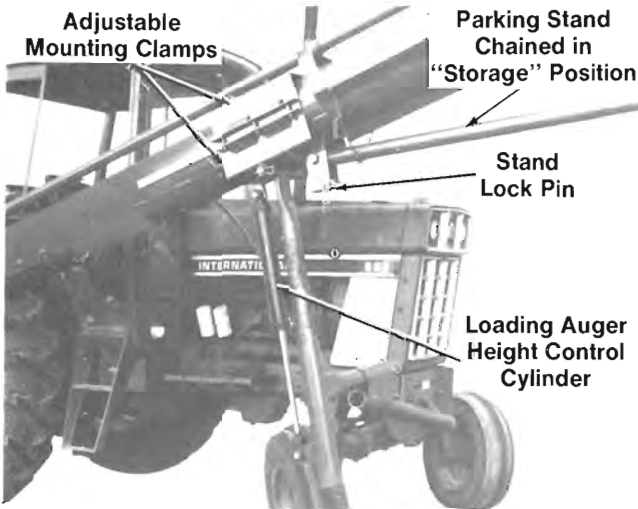

Fig. 5-4

attaching hardware is tightly secured **AT ALL TIMES** and **BE SURE** Storage Stand is locked in the "supporting" position.

Whenever the Auger is lowered, the Storage (Parking) Stand **MUST** be lowered and locked in the "supporting" position so that the weight of the Auger is resting on the Storage Stand. The Loading Auger **MUST** be supported by the Stand and the Scoop assembly **MUST** rest on the ground, before proceeding to detach the Manure Loader from the tractor.

SCOOP HEIGHT CONTROL

The height of the Scoop is controlled by the tractor 3-point hitch hydraulic control lever. Depending on the direction of movement of the 3-point hitch control lever, pulling back or up on the lever will raise the Scoop assembly off the ground and, pushing ahead or down on the lever will lower the Scoop assembly to the ground.

NOTE: For best performance, the bottom of the Scoop should be approximately 18" (455 mm) below the surface of the manure being loaded.

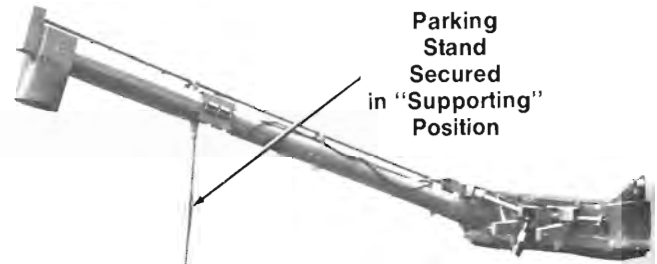

Fig. 5-5

TELESCOPING PTO DRIVES (Fig. 5-6)

Both the Telescoping Drive connection to the tractor and the Telescoping Drive connection between the two Gearboxes are equipped with rotating Shields.



WARNING: BE SURE that the Rotating Shields on both Telescoping PTO Drives turn freely **BEFORE** starting the tractor engine.

The Telescoping Drive connection to the tractor is also equipped with a Spring-loaded Locking Device to positively lock it onto the tractor PTO shaft. Slide the Locking Device against the Spring tension and slide the Yoke onto the tractor PTO shaft. Release the Locking Device and move the Yoke ahead or back until the Lock engages into the groove of the shaft.



WARNING: BE SURE that the tractor drive Telescoping PTO Coupler is properly secured to the tractor PTO shaft **BEFORE** starting the tractor engine.

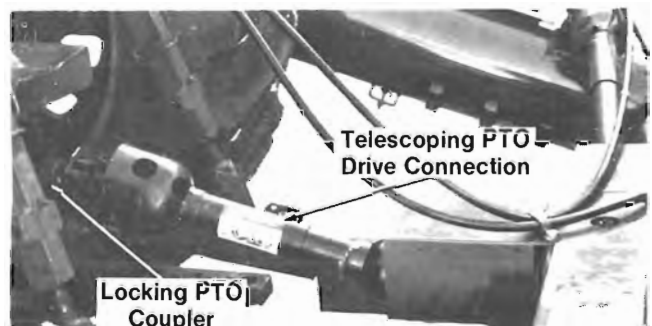

Fig. 5-6

CHAPTER 6

OPERATION

GENERAL INFORMATION (Figs. 6-1 & 6-2)

The Manure Loader is designed and constructed to handle liquid or self leveling manure. It features a Scoop Auger which breaks-up the crust and augers the manure into the Loading Auger. The height of the Scoop assembly is controlled by the tractor 3-point hitch hydraulic control. For best performance, the bottom of the Scoop assembly Housing should be approximately 18" (455 mm) below the surface of the manure. The height of the Loading Auger's discharge end is controlled by a Cylinder which is operated by a remote circuit on the tractor. The Scoop and Loading Auger are driven by the tractor's PTO shaft. The primary drive is through a "T" Gearbox and a 90° Gearbox and the final drives are #80 Roller Chains.

Emergency Shut-down

WARNING: To avoid injury, keep away from the Scoop Auger. **BE SURE** to exercise the **MANDATORY SAFETY SHUTDOWN PROCEDURE** (page 8), **BEFORE** leaving the tractor seat to correct a problem.

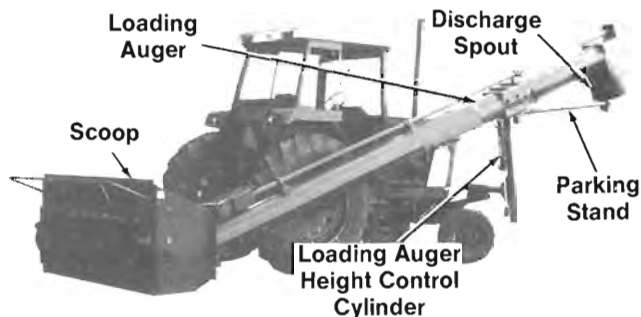

Fig. 6-1: Manure Loader Mounted on Tractor

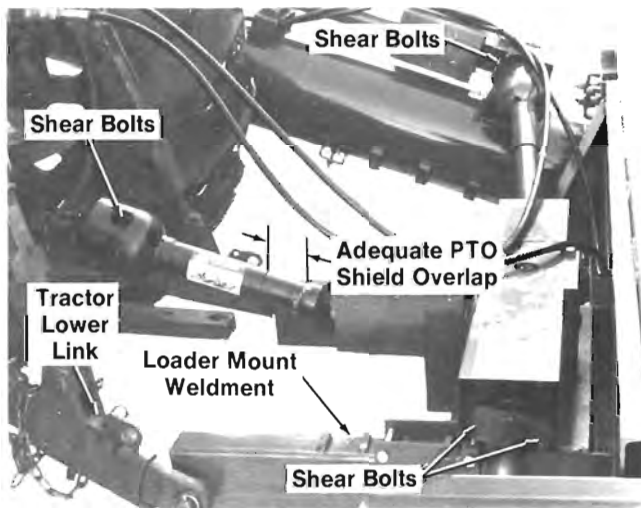

Fig. 6-2: Loader with Scoop Resting on the Ground

In an emergency or in case a foreign object becomes lodged in the Scoop or Auger areas, **STOP** operation **IMMEDIATELY** by disengaging the tractor PTO. **BE SURE** to exercise the **MANDATORY SAFETY SHUTDOWN PROCEDURE** (page 8), **BEFORE** leaving the tractor seat to correct the problem.

Tractor Mounting (Fig. 6-2)

NOTE: Proper operation of the Manure Loader requires a tractor with sufficient size and horsepower to support and power the unit.

Make the necessary adaptations, for attaching the Manure Loader to the tractor per details in the Set-up & Assembly chapter. If the Loader has been previously mounted and detached, connect the Loader Mounts (Weldments) to the tractor lower links using lynch pins with snap-lock rings. Then, attach the Telescoping PTO and necessary hydraulic connections to the tractor per the following guidelines.

PTO Connection (Figs. 6-2 & 6-3)

WARNING: **BE SURE** that the Telescoping PTO Coupler is properly secured to the tractor PTO shaft. **BE SURE** also that the Rotating Shields turn freely **BEFORE** starting the tractor engine. The length of the Telescoping PTO Shaft **MUST NEVER** be shortened.

NOTE: The Manure Loader is designed for 540 RPM PTO operation only! To prevent Drive Line damage, avoid operating at higher speeds.

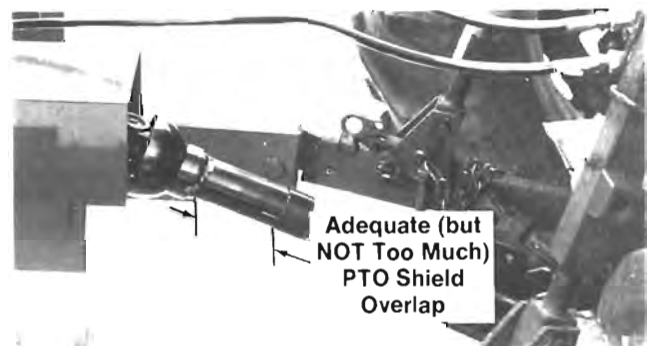

Fig. 6-3: Loader with Scoop Raised All the Way Off the Ground

When connected to the tractor, the PTO Shaft should have sufficient length so it does **NOT** bottom-out **NOR** come apart when the Scoop is raised or lowered. If either condition exists, adjust the length of the Loader Mounts (Weldments) until the correct PTO Shaft connection can be made. Slide back the Coupler Lock and attach the PTO Drive to the tractor PTO shaft. Make sure that the Coupler locks onto the shaft; slide it back and forth until it locks.

Hydraulic Connections

Before starting the tractor, make the hydraulic hose connections to appropriate remote outlet on the tractor. Then, operate the tractor valve to fill the hydraulic lines and operate the Cylinder circuit on the Loading Auger. Check the tractor fluid level after filling the Cylinder and add fluid to the tractor system, if required.

OPERATING LOADER (See Fig. 6-1)

After the proper hookup is made, start the tractor engine and engage the PTO at low idle. Lower the Scoop to the ground and then, slowly back into the manure while bringing the tractor PTO RPM up to speed until the desired flow is achieved. It may be necessary to rock back and forth to break-up the crust and to get the manure to work into the Auger. Back the Spreader or Tanker under the Discharge Spout at the same time the Loader begins to discharge the manure. The Loader should **NOT** require moving unless the flow out of the Discharge Spout stops or slows-down. Lower PTO speeds should be used with crusted semi-solid manure and higher speeds should be used with totally liquid manure.

NOTE: The speed, at which the auger should be operated, depends on the fluid viscosity of the manure, the speed of Auger rotation and, the pitch of the Loading Auger. **BE SURE** to start at a slower Auger speed until a steady flow of manure is coming out the discharge. Then, gradually increase the tractor RPM until the desired rate of loading is obtained. **Under NO** circumstances should the rated 540 RPM operating speed be exceeded.

UNPLUGGING (Fig. 6-4 & see Fig. 6-1)



WARNING: When any part of the Manure Loader becomes plugged, stop the unit **IMMEDIATELY** by disengaging the PTO. Then, exercise the **MANDATORY SAFETY SHUT-DOWN PROCEDURE** (page 8) **BEFORE** proceeding to remedy the plugging problem. **NEVER** attempt to unplug the Loader unless the PTO is disengaged, the tractor engine is **OFF**, the key is removed, the PTO is disconnected from the tractor and the Loader Scoop Housing is resting on the ground and the Loading Auger is securely resting on the Storage (Parking) Stand.

If the Loading Auger becomes plugged by a large or other type of foreign object, to unplug or remove the blockage, first lower the Scoop to the ground and the Loading Auger onto the Storage Stand. As required, remove the Auger Cleanout Door(s) to locate and remove the blockage. If a foreign object is lodged inside the Scoop, remove the Shear Bolts (if they haven't already sheared) to free the Scoop Auger so that it can be rotated to dislodge the object. After the blockage has been removed from either area, new Shear Bolts and Lock Nuts should be installed.

OVERLOAD PROTECTION (See Fig. 6-2)

Shear Bolts are used in three areas of the Manure Loader to provide overload protection.

NOTE: **BE SURE** to stop operation **IMMEDIATELY** when any Shear Bolt failure is detected.

PTO (Power Take Off)

The front half of the Telescoping PTO Drive is protected by two 5/16 x 2, Grade 5 Shear Bolts and Lock Nuts. When they are replaced, **BE SURE** to install them from the rear so that the Bolts shear thru the body rather than the threads. For replacement Shear Bolts and Lock Nuts, refer to the Optional Features & Accessories chapter. There are two probable causes for PTO Shear Bolt failure; either the PTO is being engaged at too high an RPM or, foreign object(s) wedging inside the Scoop or Loading Auger.

Scoop Auger Drive

The Drive Line Flange (Gearbox end of Shaft), between the "T" Gearbox and the Scoop Auger Drive Sprocket, is protected by two 5/16 x 2, Grade 2 Shear Bolts and Lock Nuts. When they are replaced, **BE SURE** to install them from the rear so that the Bolts shear thru the body rather than the threads. For replacement Shear Bolts and Lock Nuts, refer to the Optional Features & Accessories chapter.

There are two probable causes for Scoop Auger Drive Bolt failure; foreign object(s) wedging inside the Scoop Auger or overfeeding the Auger because the Scoop is too deep in the manure for the consistency of manure being loaded.

Loading Auger Drive

The Telescoping Drive Line to the Loading Auger 90° Gearbox is protected by two 5/16 x 2, Grade 2 Shear Bolts and Lock Nuts located inside the large bell on the Gearbox end. When Shear Bolts are replaced, install them from the rear so that the Bolts shear thru the body rather than the threads. For replacement Shear Bolts and Lock Nuts, refer to the Optional Features & Accessories chapter. The probable cause for Loading Auger Drive Bolt failure is foreign object(s) wedging inside the Loading Auger tube.

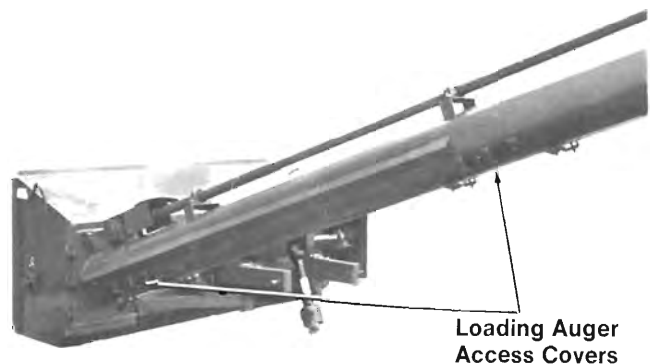

Fig. 6-4

CHAPTER 7

ADJUSTMENTS



CAUTION: BEFORE proceeding to perform any adjustments on the Manure Loader, exercise the **MANDATORY SAFETY SHUT-DOWN PROCEDURE** (page 8).

SCOOP AUGER DRIVE CHAIN (Fig. 7-1)

To adjust the Chain tension on the Scoop Auger Drive, first loosen (but do **NOT** remove) the Pillow Block attachment

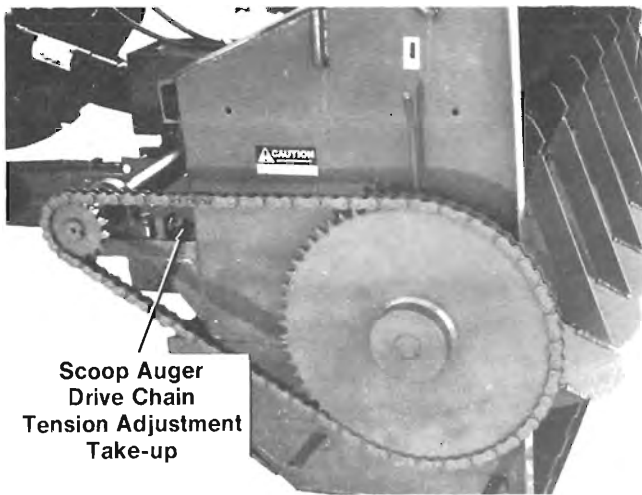

Fig. 7-1

hardware. Then, adjust the Take-up Bolt to reposition the Bearing and obtain the desired tension. After proper tension is obtained, tightly secure the Pillow Block attachment hardware.

LOADING AUGER DRIVE CHAIN (Fig. 7-2)

To adjust the Chain tension on the Loading Auger Drive Pillow Block Bearing, Shims **MUST** be added or removed from beneath the Pillow Block. After the desired tension is obtained, tightly secure the Pillow Block attachment hardware.

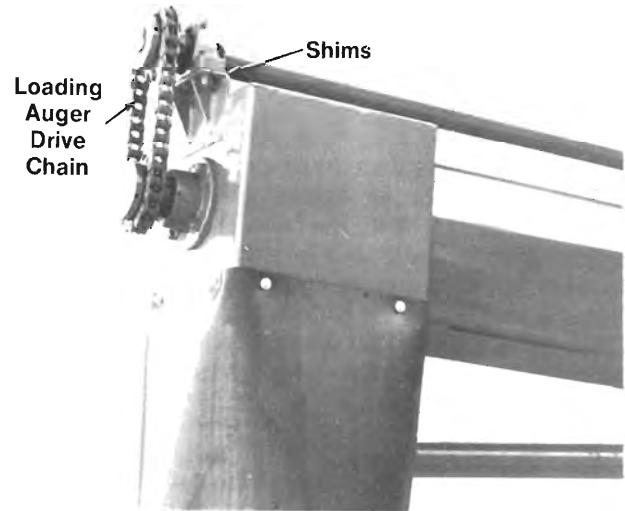

Fig. 7-2

CHAPTER 8

LUBRICATION

GENERAL INFORMATION

CAUTION: NEVER attempt to lubricate the machine when any part of the unit is in motion. ALWAYS BE SURE to exercise the MANDATORY SAFETY SHUTDOWN PROCEDURE (page 8) BEFORE proceeding to lubricate the machine. BE SURE that the Scoop Housing is resting on the ground and that the Loading Auger is resting on the Storage (Parking) Stand.

It is well to remember that a sufficient amount of grease will prevent excessive part wear and early failure.

GEARBOXES

The Manure Loader is provided with two Gearboxes. The Loader is shipped dry from the factory with **NO** lubricant in either Gearbox. After the Loader is setup, the Gearboxes **MUST** be filled with EP90 Gear Lube. The 90° Gearbox has a capacity of approximately 1-1/2 Pints and the Tee-style Main Drive Gearbox has a capacity of approximately 3 Quarts. The oil level in both Gearboxes should be maintained at the bottom of the Fill Plug opening. The oil level in each Gearbox should be checked at the beginning and end of each season of operation.

OILING

Lubricate all Drive Chains every 6 to 8 hours of operation using a good grade of foaming aerosol lubricant, such as NAPA Chain and Cable Lubricant. This type of lubricant increases the life of the Chain 3 to 4 times over those lubricated at 8 hour intervals with new or used motor oil. The recommended method is to spray the entire length of Chain on the center of the Rollers. It is better to lubricate Chains when they are warm (after use, rather than before).

GREASING

NOTE: Grease all fittings at the intervals of operation listed. Use a good grade of lithium-base grease. For all Shear Flanges, grease each time Bolts shear or at least once a year. The Loading Auger Height Control Cylinder Shaft should also be frequently coated with a rust preventative spray or lubricant.

Wipe dirt from the fittings before greasing to prevent any dirt from being forced into the Bearings or pivots. Replace any missing fittings, when noted. To minimize dirt build-up, avoid excessive greasing.

Lubricate Every 10 hours (or Daily)

1. Loading Auger Drive Shaft Pillow Block Bearings (4 Places)
2. Loading Auger Support Bearings (2 Places)
3. Loading Auger Support Pivot (2 Places)
4. Scoop Auger Drive Shaft Pillow Block Bearing
5. Scoop Auger Support Bearings (2 Places)
6. U-joint Crosses (6 Places)

Lubricate Every 50 hours

7. Telescoping PTO Drive Tubes (2 Places)
8. Shear Flange Pilot Areas (3 Places)

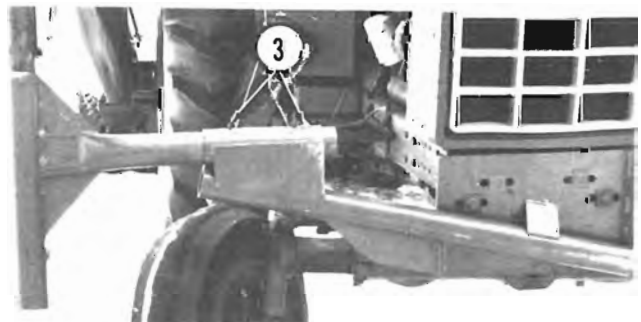
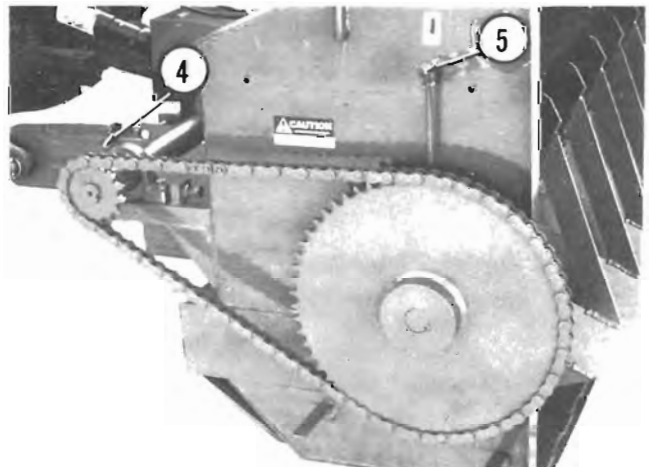
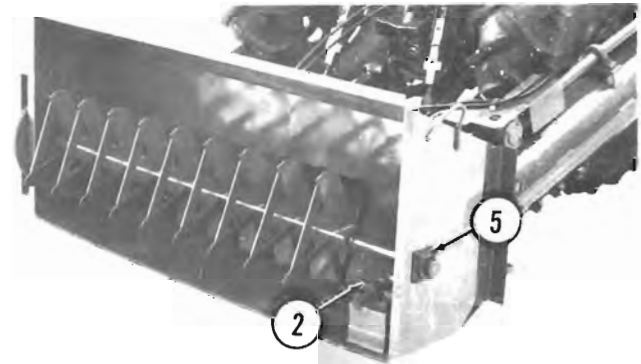
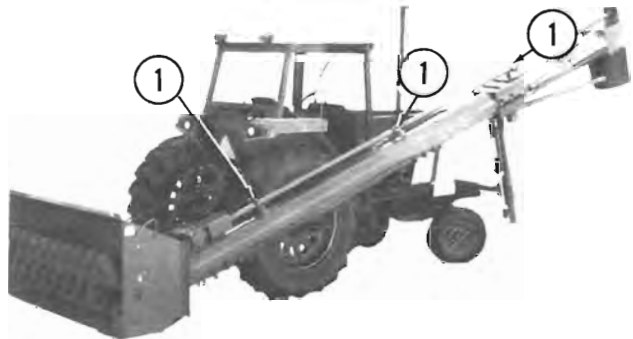

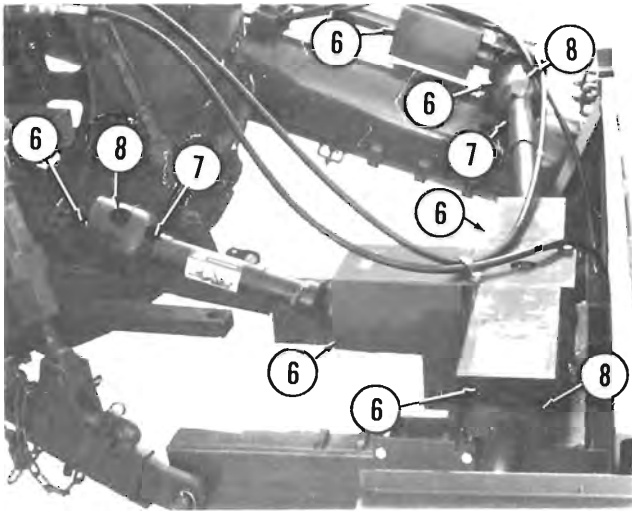

CHAPTER 9 SERVICE

 **CAUTION: BEFORE proceeding to perform all Service routines on this unit, exercise the MANDATORY SAFETY SHUTDOWN PROCEDURE (page 8).**

SET SCREWS

All of the Drive Line U-joints are secured to their respective Drive Shafts with a pair of Set Screws. The Set Screws should be maintained tightly secured and checked every other load for the first 20 loads and at regular 8 hour operating intervals thereafter.

CHAPTER 10 PREPARING FOR FIELD OPERATION

A Manure Loader is a "direct drive" machine which operates immediately after the tractor PTO is engaged. Drive disengagement is strictly by shutting-off the tractor PTO. For this reason, it is most important that shock-loading be avoided by making sure that PTO is engaged at low tractor RPM. Shear Bolt overload protection is provided for all three Drive Shafts. To facilitate proper operation and help prevent PTO Shear Bolt failure, establish and maintain the proper Drive Line alignment and tractor hookup. Refer to the Operation chapter for additional details.

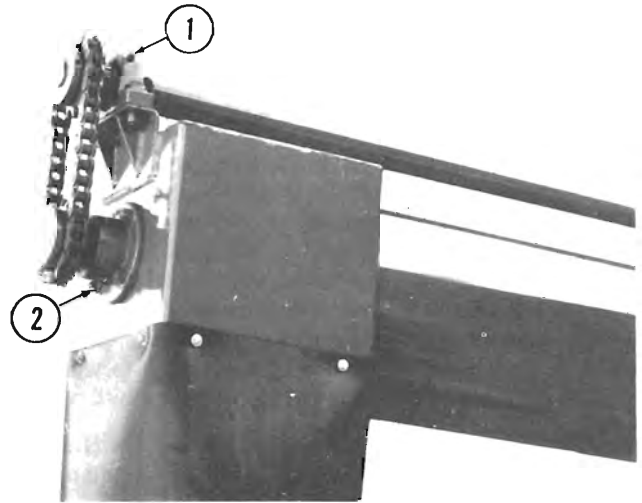

CHAPTER 11 STORAGE

Because the Manure Loader is an implement that is used only in non-freezing temperatures it should be made ready to operate before it is placed into winter storage. This involves cleaning the unit at the end of each season and lubricating all of the fittings; refer to the Lubrication chapter. For best results, it is advisable to use a pressure washer to thoroughly remove the manure. For cleaning the inside of the Loading Auger Tube, dip a couple flakes of baled straw in oil and run them through the Tube. **BE SURE** the unit is completely dry before placing it into storage; preferably inside a shed and away from the elements.

CHAPTER 12 OPTIONAL FEATURES & ACCESSORIES

SHEAR BOLTS

Shear Bolts are used to provide overload protection in three areas on the Manure Loader. The front half of the Telescoping PTO Drive is protected by two 5/16 x 2, Grade 5 Shear Bolts and Lock Nuts. The Drive Line Flange between the "T" Gearbox and the Scoop Auger Drive Sprocket is protected by two 5/16 x 2, Grade 2 Shear Bolts and Lock Nuts. The Telescoping Drive Line to the Loading Auger 90° Gearbox is protected by two 5/16 x 2, Grade 2 Shear Bolts and Lock Nuts. Replacement Shear Bolts and Lock Nuts are available in packaged quantities of eight (8) Bolts and Locknuts by the following numbers:

900014 for (8) 5/16 x 2, Grade 5 Bolts and Locknuts or.
900087 for (8) 5/16 x 2, Grade 2 Bolts and Locknuts.

NOTE: **BE SURE** to use the correct Grade Bolts in each location; refer to the Operation chapter for additional details.

CHAPTER 13

SET-UP & ASSEMBLY

The Manure Loader is shipped disassembled and banded to pallets to facilitate shipment. When received, the components **MUST** be unbanded and arranged in appropriate assemblies to facilitate interconnection. Procedures established in this set-up instruction are given in a step-by-step manner. To simplify and speed-up the assembly process, it is recommended that at least two men work together to perform these procedures. Assembly should be performed inside an enclosed workshop which is equipped with the proper tools and an overhead hoist.

NOTE: Gearboxes are shipped dry and **MUST** be filled to the proper levels **BEFORE** attempting to operate the Manure Loader.

Refer to the illustrations provided and the following steps to assemble the Manure Loader and mount it onto the appropriate-sized tractor:

- To attach the Loading Auger assembly to the Scoop Auger assembly, it will be necessary to use a hoist to move the Loading Auger assembly into position for attachment to the Scoop assembly. Wrap the hoist chain around the Loading Auger Tube by the lower two Cleanout Cover Clamps at the upper Cleanout Cover location. Position the chain on the lower side of the other Clamp to keep the chain from sliding on the Auger Tube.
 - Turn the Loading Auger so the trimmed portion of the Flighting, on the bottom end of the Auger, is facing downward. Position the bottom of the 5/8" thick Loading Auger Mounting Plate between the square stock and channel on the Scoop assembly.
 - Attach the Loading Auger assembly to the Scoop assembly with the five (5) Auger Tube Clamps, three (3) Auger Tube Side Clamps, eight (8) Plain Washers and eight (8) Locknuts.
 - Slide the Pillow Block Bearing onto the Auger Shaft. Bearings can be installed with the Lock Collar facing either way. Attach the Bearing to the Mounting Plate inside the Scoop assembly using two (2) each 1/2 x 2-1/4 Cap Screws, Plain Washers and Locknuts. Securely tighten the Set Screws on the Lock Collars.
 - Check the clearance between the Auger Flighting and the inside of the Auger Tube. Auger should be adjusted so it clears Tube. Auger is adjusted by loosening the Auger Tube Clamps and sliding the Tube left or right or by loosening the hardware, holding the Pillow Block Bearing, and sliding the Bearing left or right. If necessary, shim the Pillow Block Bearing to get clearance on the lower side of the Auger.
- NOTE:** A combination of these adjustments may also be required.
- Attach the PTO Shaft between the Tee Gearbox and the 90° Gearbox using one (1) 5/16 x 2 Square Key in the 90° Gearbox Shaft, one (1) 3/8 x 2 Square Key in the Tee Gearbox Shaft and four (4) 3/8 x 1 Square Head Set Screws and Hexagon Nuts.
 - Attach the PTO Shaft to the front of the Tee Gearbox using one (1) 3/8 x 2 Square Key and (2) 3/8 x 1 Square Head Set Screws and Hexagon Nuts.
 - Attach the Gearbox Shield to the 90° Gearbox using two (2) each 1/2 x 1 Cap Screws and Lock Washers. Leave the inside Cap Screw loose for installing a Hose Clamp later.
 - Attach the Gearbox Shield to the Tee Gearbox using two (2) each 1/2 x 1 Cap Screws and Lock Washers. Leave the front Cap Screw loose for installing a Hose Clamp later.
 - Attach the End Shield to the Sprocket Shield. Slide the lipped-portion of the End Shield over the Sprocket Shield and attach it to the Sprocket Shield with one (1) each 5/16 x 5/8 Cap Screw, Lock Washer and Hexagon Nut.
 - Attach the Sprocket Shield to the left side of the Scoop Auger assembly using four (4) each 3/8 x 1 Cap Screws, Lock Washers and Hexagon Nuts.
 - Assemble the Hinge Brackets to the Scoop Auger Drive Shaft Guard using two (2) each 5/16 x 5/8 Cap Screws, Lock Washers and Hexagon Nuts. Attach the Scoop Auger Drive Shaft Guard to the welded Hinge on the Tee Gearbox Shield using the Hinge Pin and two (2) Cotter Pins. Assemble the Lynch Pin and Chain to the Guard with a Cotter Pin and secure the Scoop Auger Drive Shaft Guard over the Pin on the End Shield which was secured to the Sprocket Shield.
 - Attach the Bumper to the sides of the Scoop assembly with four (4) each 1/2 x 1-1/4 Cap Screws, Lock Washers and Hexagon Nuts.
 - Attach the Loading Auger Sprocket Shield to the end of the Auger Tube using two (2) each 3/8 x 1 Cap Screws, Lock Washers and Hexagon Nuts.
 - Attach the Rubber Equalizer Skirt using eight (8) each 1/4 x 3/4 Cap Screws, Plain Washers and Locknuts. The cutout portion of the Rubber goes to the rear and in front of the channel on the bottom of the Auger Tube. Assemble the two ends together using three (3) each 1/4 x 3/4 Cap Screws, Plain Washers and Locknuts.
 - Bolt the Tractor Mount Weldment to the front of the tractor using the four (4) Grade 8 3/4" Bolts supplied.
- NOTE:** As required, modify Mount or front of tractor to enable using all four Grade 8 Bolts.
- Assemble the Clamp Halves to the Loading Auger Tube using six (6) each 1/2 x 3 Cap Screws and Locknuts. Clamps should be positioned on the Auger Tube with the top ends approximately 1 to 3" below the upper Split Bearing Bracket. Tighten the Cap Screws enough to hold the Clamps in place.

- Attach the Loader assembly to the tractor. The right side tractor wheel may have to be moved before the Loader can be mounted. The 2-point Loader Mount Weldments can be mounted using four (4) each 1/2 x 4-1/2 Cap Screws and Lock Nuts. Position the Weldments so that the PTO Shaft can be assembled. After proper position is established, secure the hardware and install the Lynch Pins.

NOTE: Overall length of the PTO Shaft should NOT exceed 36".

- Slide the Pivot Tube through the Upper Pipe on the Tractor Mount Weldment and install one (1) each 3/8 x 4 Cap Screw and Locknut.
- Place the Extending Pipe Weldment into the Pivot Tube Weldment. Raise the Extending Pipe so it can be placed between and aligned with the Brace Pin and secure it with two (2) Hairpin Cotter Pins.
- Raise the Auger Tube as necessary to assemble the hydraulic Cylinder. Install the Swivel Adapters in the Cylinder. Use thread-sealing compound or tape on all hydraulic connections.
- Attach the Auger Parking Stand to the bottom of the Auger Tube Clamp using the Pivot Bolt, Slotted Nut and Cotter Pin. The Parking Stand is used to support the Auger Tube when it is disconnected from the tractor. **BE SURE** that when the Parking Stand is lowered, it is

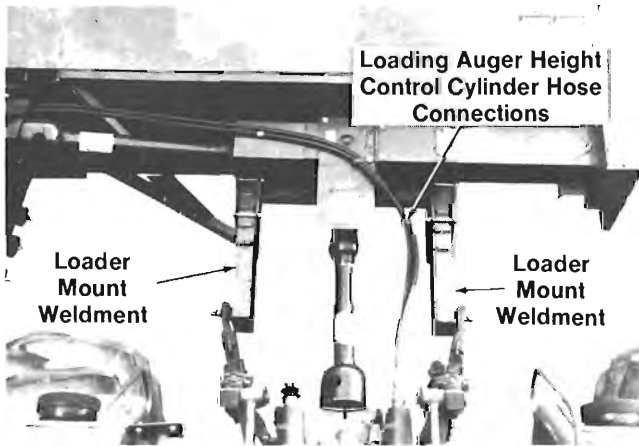

Fig. 13-1

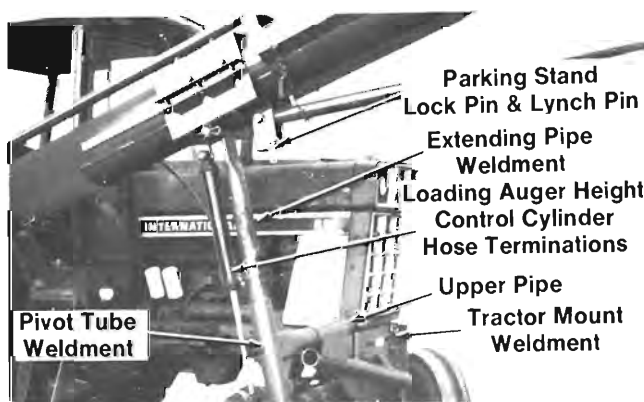

Fig. 13-2

securely locked in the "supporting" position with the Lock Pin and Lynchpin. When the Loader is mounted and in operation, the Stand should be swung-up and secured with the Storage Chain on the Auger Tube.

- Adjust the Auger Tube Clamps ahead or back, as necessary, so that the Support Pipe is as close as possible to perpendicular or 90° to the Auger Tube when the hydraulic Cylinder is in the retracted position. Then, tighten the Clamp Bolts.
- Attach the hydraulic Hoses to the Swivel Adapters. Route the Hoses through Hooks on the inside of the Auger Tube and through the rear two Bearing Brackets for the Loading Auger Drive Shaft. Remove the inside Bolt from the 90° Gearbox and the front Bolt from the Tee Gearbox. Anchor the Hoses to both Gearboxes with the Clamps provided. Attach the ends of the Hoses to the Cylinder and install appropriate disconnect fittings (**NOT** supplied) to the other ends which connect to the tractor hydraulic outlet.
- Remove the Fill/Breather Plugs and Oil Level Plugs in the two Gearboxes and fill them with EP90 gear lube until the oil starts coming out of the Oil Level Plug holes. Reinstall and securely tighten the Plugs. The oil capacity for the 90° Gearbox is approximately 1-1/2 pints and for the Tee Gearbox is approximately 3 quarts. Grease the PTO Shafts, the U-joints, Bearings and the two fittings on the Tractor Mount Upper Pipe. Remove the overhead hoist chain and proceed to testrun the Loader.

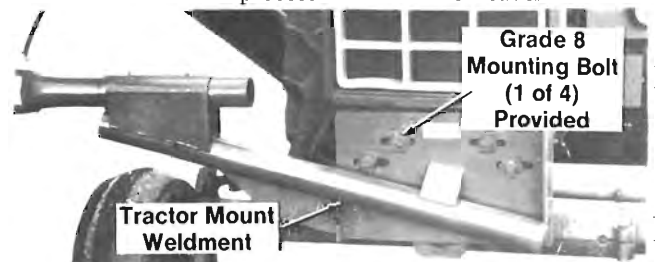

Fig. 13-3

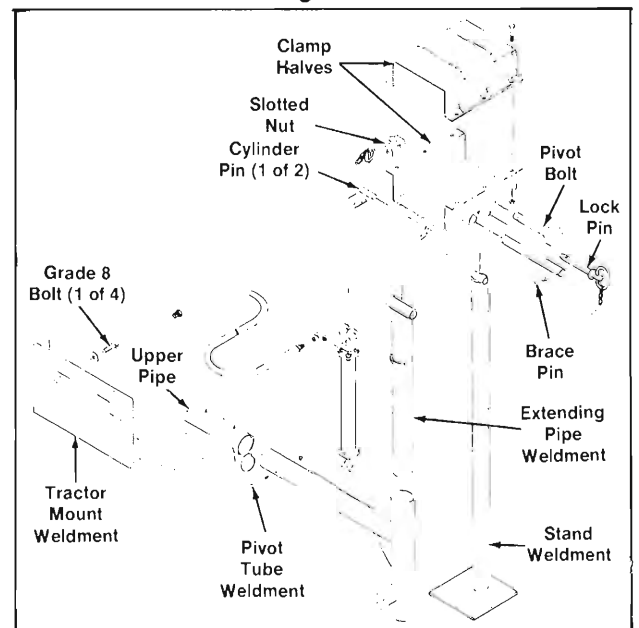

Fig. 13-4

Loading Auger Assembly

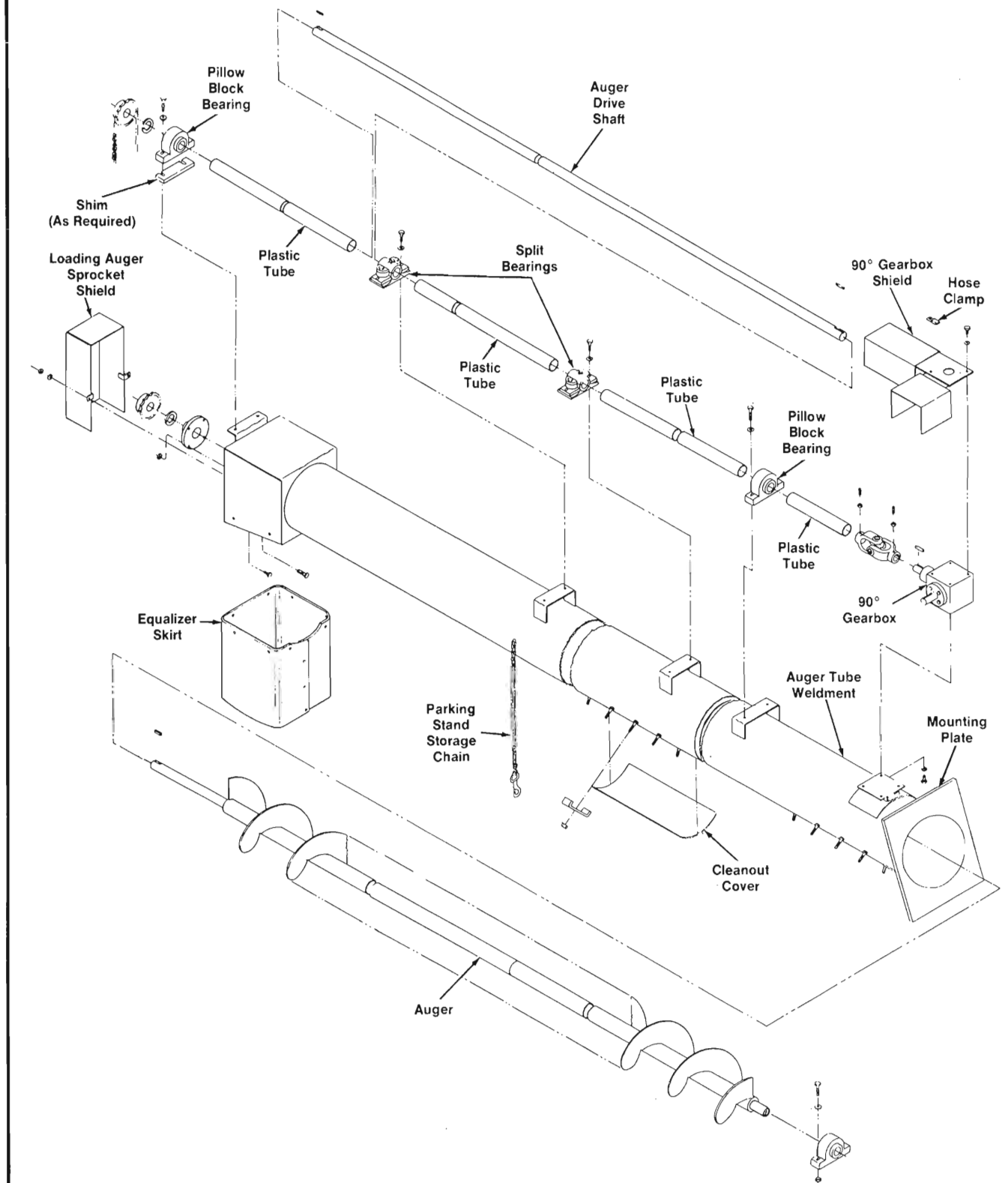

Fig. 13-5

Scoop Assembly

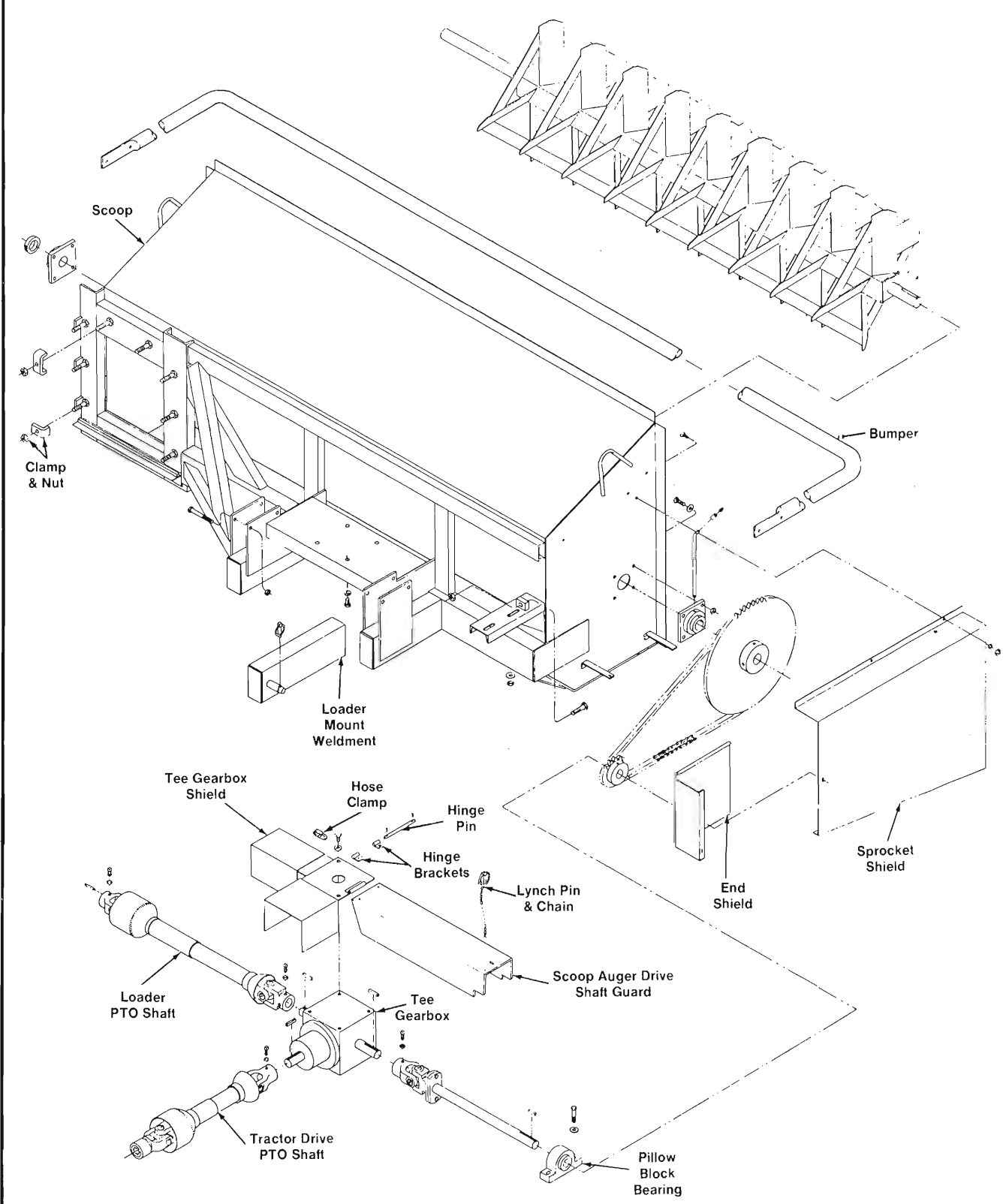

Fig. 13-6

CHAPTER 14

DECAL LOCATIONS

GENERAL INFORMATION

Decal Location information is provided to assist you in the proper selection and application of new decals, in the event the original decals become damaged or the machine is repainted. Refer to the appropriate illustration to determine the reference number of the desired decal. Then, using the reference number, refer to the listing to determine the part number, description and quantity.

NOTE: Refer to the SAFETY Chapter for the specific information provided on all of the various Safety Decals provided in the Decal Kit(s).

To ensure proper selection of the correct replacement decals, carefully review all of the illustrations which pertain to your machine **BEFORE** starting to refinish the unit. Circle each decal reference number for the decals which will require replacement and then check it off in parts list.

CAUTION

ALWAYS read and abide by the Safety Rules and Information shown on Decals. If Decal(s) become damaged, unreadable or if the unit is repainted, the Decal(s) **MUST** be replaced. When repainting, **MAKE SURE** that **ALL** Decals which apply to your machine are readable and are properly affixed to the machine in their original locations.

NEW DECAL APPLICATION

Surfaces **MUST** be free from dirt, dust, grease and other foreign material **BEFORE** applying the new decal. To apply a solid-formed decal, remove the smaller portion of the decal backing paper and apply the exposed adhesive backing to the clean surface while maintaining proper position and alignment. Then, peel the remaining portion of the backing paper off slowly while applying hand pressure to smooth-out the decal surface.

Refer to the paragraph just before the decal listing to determine the proper Decal Set Number for your machine.

PAINT NOTICE

Use this list to order paint for refinishing:

901225	One Gallon Blaze Paint
901226	One Gallon Maize Paint
610239	6 (12oz Spray Cans) Blaze Paint
610240	6 (12oz Spray Cans) Maize Paint

The Decal Set Number for the L22 Manure Loader is 080912. The Set includes the following:

Ref. No.	Part No.	Description & Quantity
1	058627	Decal - Transmission Shipped Dry (2 Places) - Replacement NOT necessary
2	061187	Decal - Grease Fitting Symbol (6 Places)
3	072058	CAUTION - Close or Replace Guard - (3 Places)
4	072148	DANGER - Avoid Electrical Contact
5	072149	DANGER - Rotating Components (2 Places)
6	073671	CAUTION - 540 RPM Operation Only
7	076894	CAUTION - Operator's Responsibility & Read Manual
8	077682	CAUTION - General Safety Precautions
9	080126	DANGER - Rotating Drive Line (2 Places)
10	080127	WARNING - Rotating Drive Line
11	080247	Decal - NO Step
12	080891	Decal - Use 4 Grade 8 Bolts
13	081145	DANGER - Manure Gas (2 Places)
14	061201	GEHL (2 Places)
15	080892	GEHL22 (2 Places)

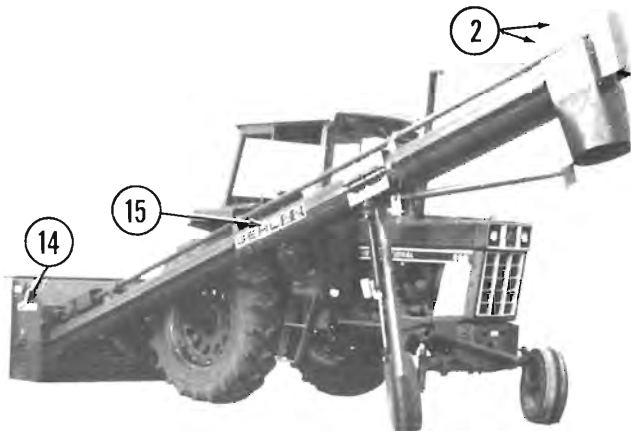

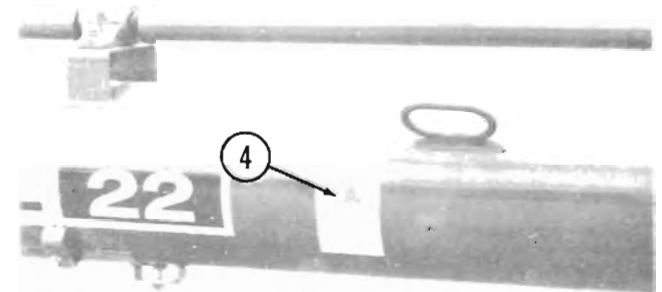
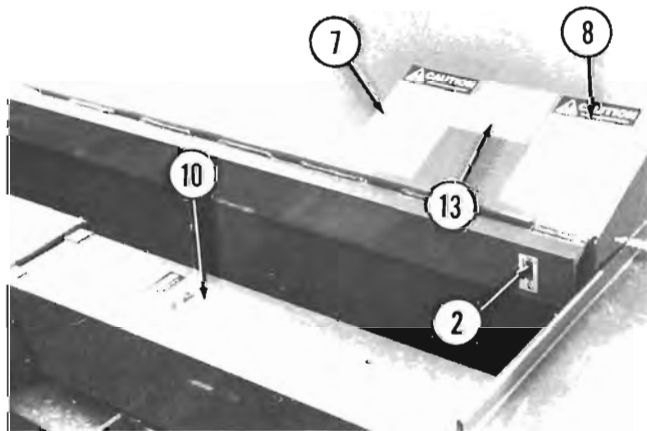
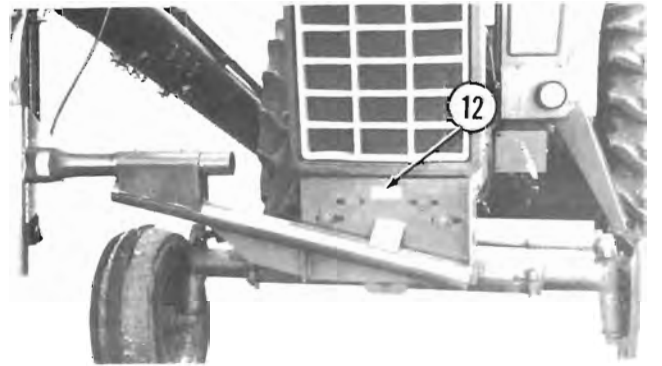
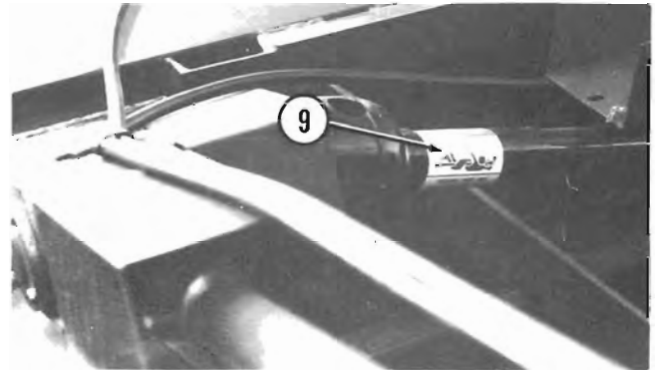
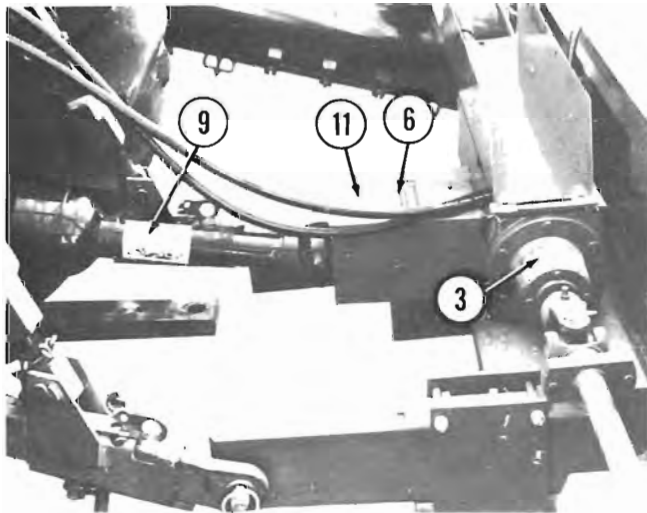
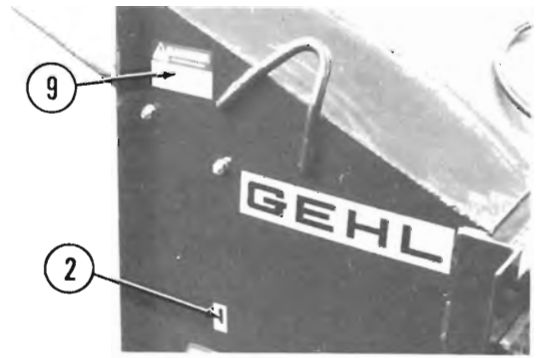
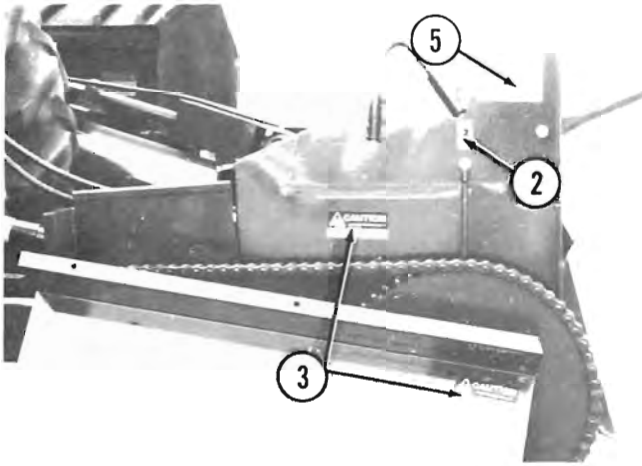

CHAPTER 15

SERVICE PARTS & NUMERICAL INDEX

When ordering service parts, specify the correct part number, full description, quantity required, the unit model number and serial number.

Common attaching hardware, such as Cotter Pins, Set Screws, Woodruff Keys, Screws, Nuts, etc., are included in the parts lists, indented below the part it is (they are) associated with.

Unless otherwise noted, the standard fastening procedure is to secure two parts with a CS, L and N. A part with a mounting slot should be secured with a P against the slotted surfaces. LN's are sometimes used to prevent two parts from separating but still to allow one part to move or rotate next to the other.

NOTE: The following abbreviations are used herein:

- CS - Cap Screw (Hexagon Head)
- SHSS - Socket Head Set Screw

- SQHSS - Square Head Set Screw
- N - Nut (Hexagon)
- JN - Jam Nut (Hexagon)
- LN - Lock Nut (Hexagon)
- SN - Slotted Nut (Hexagon)
- L - Lock (Washer)
- P - Plain (Washer)
- ASS'D - Assembled
- ASS'Y - Assembly
- BRG - Bearing
- DEG. - Degree
- GR - Grade
- L.H. - Left Hand
- NPT - National Pipe Thread
- PTO - Power Take Off
- R.H. - Right Hand
- SL - Self Locking (Thread)
- SQ - Square
- T - Tooth (Teeth)
- W/ - With

L22 - LIFT SYSTEM & PARKING STAND

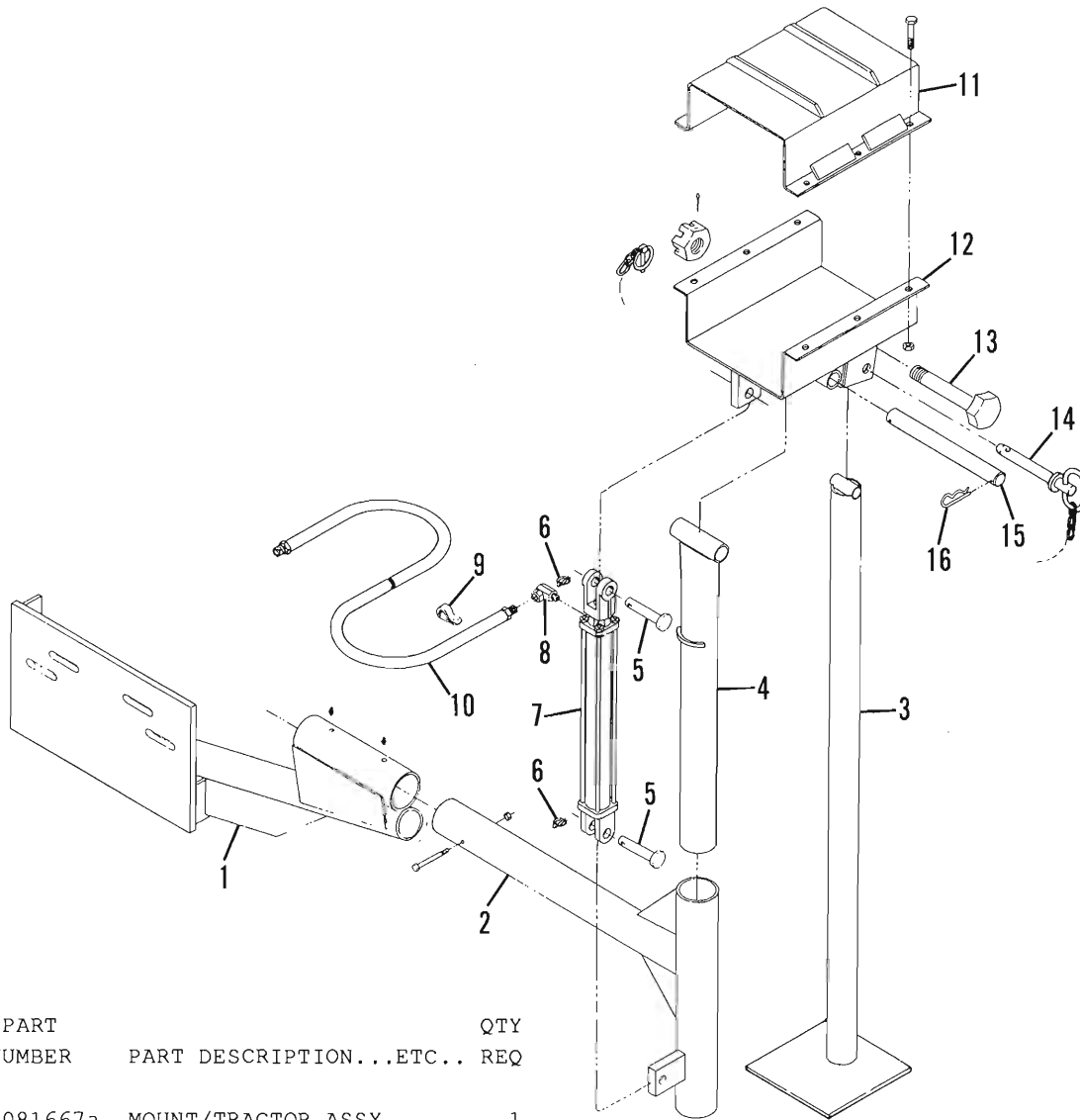

REF NO	PART NUMBER	PART DESCRIPTION...ETC..	QTY REQ
01	081667a	MOUNT/TRACTOR ASSY.....	1
	570002	FITTING/GREASE.....	1
	061267	CS 3/4X2-1/2 GR.8.....	4
02	081662	TUBE/PIVOT ASSY.....	1
	650742	CS 3/8X4 (LN).....	1
03	081639	STAND/AUGER ASSY.....	1
04	081658	PIPE/EXTENDING ASSY.....	1
05	060629	PIN/CYLINDER-REPLACEMENT.	2
06	060471	PIN/KLIK -REPLACEMENT....	2
07	606086b	2 X 18 HYDRAULIC CYLINDER	1
08	083290	UNION/90 DEG SWIVEL ADAP. (LATER)	2
	580116	UNION/90 SWIVEL ADAPTER.. (EARLY)	2
09	067880c	CLAMP/DOUBLE HOSE.....	2
10	606223	HOSE/ASSEMBLY 3/8X188"...	2
11	081648	CLAMP/HALF TOP ASSY.....	1
	650644	CS 1/2X3 (LN).....	6
12	081643	CLAMP/HALF BOTTOM ASSY...	1

REF NO	PART NUMBER	PART DESCRIPTION...ETC..	QTY REQ
13	070880	PIN/HITCH.....	1
	655022	PIN/COTTER 3/16X1-3/4... (1) 1 SN	1
14	080914	PIN/HITCH.....	1
15	606234	PIN/BRACE.....	1
16	9H 300	PIN/HAIRPIN COTTER.....	2

a) CONTAINS HARDWARE NOTICE DECAL 080891.

b) FOR SEAL KIT, ORDER PART NUMBER 606239.

c) TWO 073535 CLAMPS CAN ALSO BE USED.

L22 - SCOOP ASSEMBLY

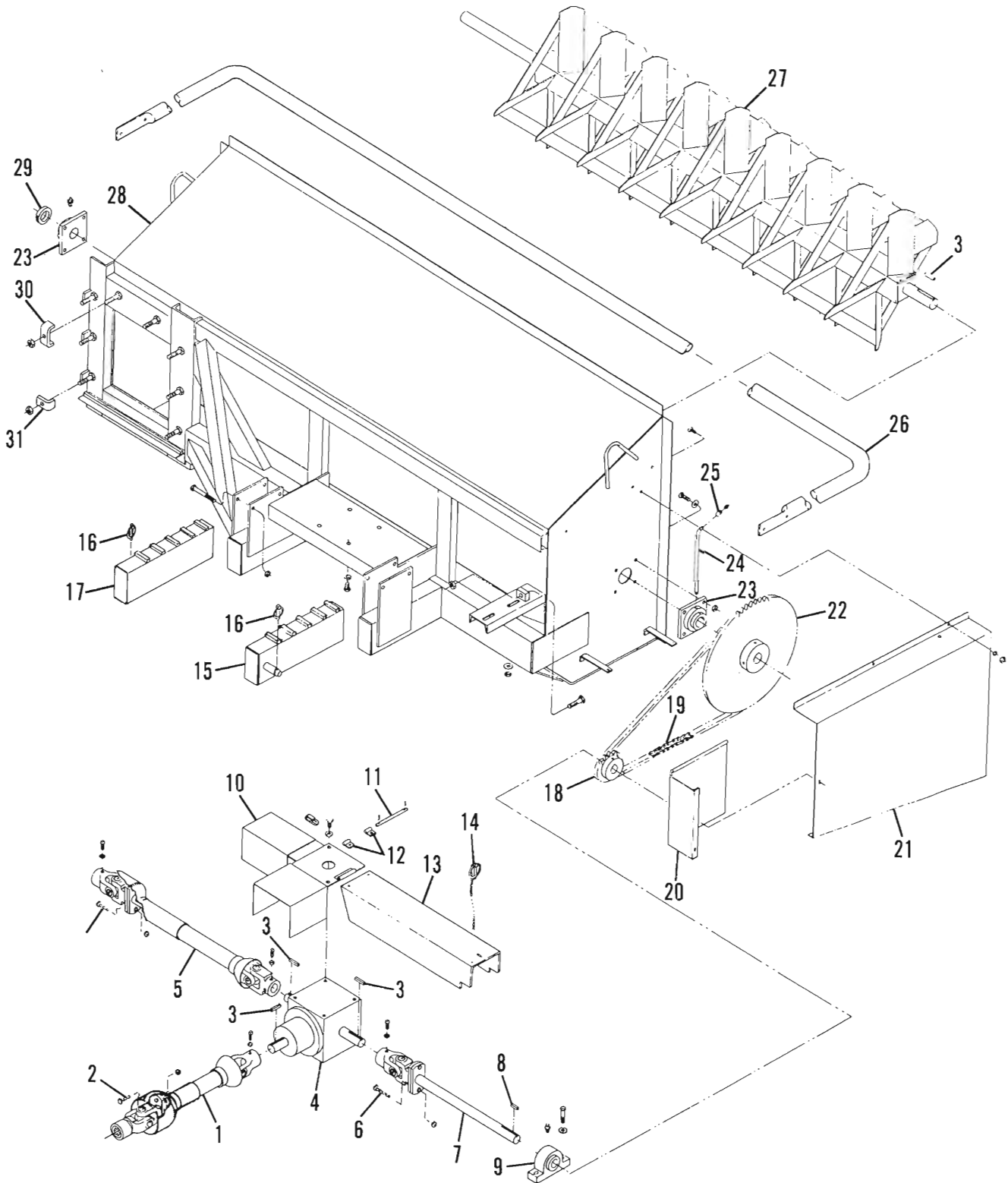

L22 - SCOOP ASSEMBLY

REF NO	PART NUMBER	PART DESCRIPTION...ETC..	QTY REQ	REF NO	PART NUMBER	PART DESCRIPTION...ETC..	QTY REQ
01	081677a	SHAFT/PTO W/SAFETY YOKE..	1	20	081701	GUARD/ASSY.....	1
	650231	SQHSS 3/8X1 (N).....	2		650485	CS 5/16X5/8 (N,L).....	1
02	062372b	SHEAR BOLT 5/16X2 GRADE 5 (2) 5/16LN	2	21	081691	SHIELD/SPROCKET.....	1
					650490	CS 3/8X1 (N,L).....	4
03	056230	KEY 3/8SQ. X 2.....	4	22	606095	SPROCKET 60T.....	1
04	606098c	GEARBOX - T STYLE.....	1		650217	SHSS-SL 3/8X3/4.....	2
	650495	CS 1/2X1-1/4 (L).....	4	23	606087	HOUSING/BRG ASSM'D.....	2
05	606100a	PTO SHAFT.....	1		570002	FITTING/GREASE.....	1
	650231	SQHSS 3/8X1 (N).....	4		650453	CS 1/2X1-1/2 (LN,P).....	8
06	061699d	SHEAR BOLT 5/16X2 GRADE 2 (4) 5/16LN	4	24	081576	PIPE/GREASE.....	1
				25	660025	PIPE/COUPLING 1/8 NPT....	1
07	606084a	SHAFT.....	1		570002	FITTING/GREASE.....	1
	650231	SQHSS 3/8X1 (N).....	2	26	081697	BUMPER.....	1
08	059566	KEY 3/8 SQ. X 1-1/2.....	2		650494	CS 1/2X1 (N,L).....	4
09	606090	HOUSING/BRG.....	1	27	081578	AUGER/ASSY CROSS.....	1
	570002	FITTING/GREASE.....	1	28	606140	SCOOP WELDMENT COMPLETE..	1
	650805	CS 1/2X2-3/4 (LN,4P)....	2	29	606091	LOCK COLLAR 1-3/4.....	1
	650694	CS 5/8X2-1/2 (JN).....	1	30	606136	CLAMP/AUGER TUBE.....	5
10	081693	SHIELD/GEAR BOX ASSY.....	1			(5) 5/8LN	
	650494	CS 1/2X1 (L).....	2	31	606137	CLAMP/SIDE AUGER TUBE....	3
11	081700	PIN/HINGE.....	1			(3) 5/8LN	
12	081699	HINGE.....	2				
	650485	CS 5/16X5/8 (N,L).....	2				
13	081698	GUARD.....	1				
14	064861	PIN/KLIK.....	1				
	650553	PIN/COTTER 1/8X3/4.....	4				
15	082266	MOUNT/ASSY 2 POINT-LEFT..	1				
	650653	CS 1/2X4-1/2 (LN).....	2				
16	060471	PIN/KLIK.....	2				
17	606131	MOUNT/ASSY 2 POINT-RIGHT.	1				
	650653	CS 1/2X4-1/2 (LN).....	2				
18	606093	SPROCKET 15T.....	1				
	650217	SHSS-SL 3/8X3/4.....	2				
19	606097	CHAIN/ROLLER (#80) OF 91. LINKS INCLUDING ONE 50019 PLAIN CONNECTOR & ONE 048728 OFFSET CONNECTOR.	1				

a) FOR COMPONENTS, SEE PAGES TITLED
UNIVERSAL DRIVES.

b) FOR REPLACEMENT SHEAR BOLTS, ORDER
900014 FOR A PACKAGE OF 8 BOLTS
& LN.

c) FOR COMPONENTS, SEE PAGES TITLED
GEARBOXES.

d) FOR REPLACEMENT SHEAR BOLTS, ORDER
900087 FOR A PACKAGE OF 8 BOLTS
& LN.

L22 - LOADING AUGER ASSEMBLY

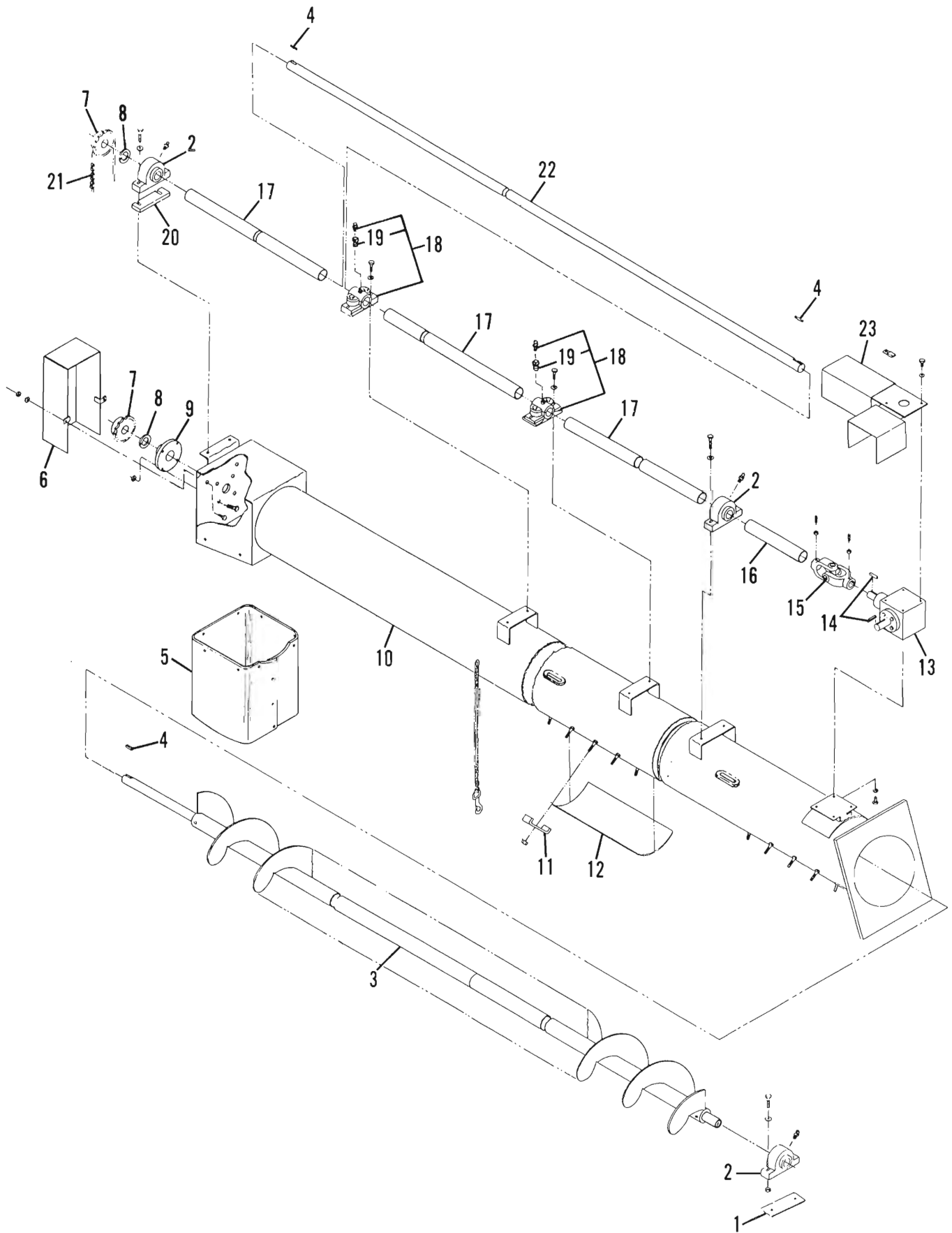

L22 - LOADING AUGER ASSEMBLY

REF NO	PART NUMBER	PART DESCRIPTION...ETC..	QTY REQ	REF NO	PART NUMBER	PART DESCRIPTION...ETC..	QTY REQ
01	084377	SHIM.....	AR	14	056230	KEY 3/8SQ. X 2.....	3
02	606089	BEARING.....	3	15	606101b	35 SERIES U-JOINT.....	1
	570005	FITTING/GREASE.....	3		650231	SQHSS 3/8X1 (N).....	4
	650502	CS 1/2X2-1/4 (LN,P).....	6	16	606135	SHIELD/SHAFT.....	2
03	081623	AUGER/LOADING ASSY.....	1	17	081634	GUARD/DRIVE SHAFT MIDDLE.	3
04	B 11221	KEY 5/16SQ. X 2.....	2	18	606132	1-3/4 SPLIT JOURNAL BRG..	2
05	081707	SKIRT/EQUALIZER.....	1		650585	CS 1/2X2 (LN,P).....	4
	650448	CS 1/4X3/4 (LN,14P).....	11	19	660043	BUSHING.....	2
06	081680	SHIELD/AUGER SPROCKET ASS	1		570002	FITTING/GREASE.....	2
	650490	CS 3/8X1 (N,L).....	2	20	081706	SHIM.....	1
07	606094	SPROCKET.....	2	21	606096	CHAIN/ROLLER (#80) OF 36.	1
08	606091	LOCK COLLAR 1-3/4.....	2			LINKS INCLUDING ONE 50019	
09	606088	BEARING & COLLAR ASSY....	1			PLAIN CONNECTOR.	
10	081592	TUBE/AUGER ASSY.....	1	22	081635	SHAFT/DRIVE LONG.....	1
11	606134	CLAMP/COVER.....	20	23	081686	SHIELD/GEAR BOX ASSY....	1
		(20) 1/2LN			650494	CS 1/2X1 (L).....	2
12	081630	COVER/CLEAN-OUT OPENING..	2				
13	084540a	TRANS/RT ANGLE BEVEL.....	1				
		(LATER)					
	606102	GEARBOX - 90 DEG. (EARLY)	1				
	650494	CS 1/2X1 (L).....	4				

a) FOR COMPONENTS, SEE PAGES TITLED GEARBOXES.

b) FOR COMPONENTS, SEE PAGES TITLED UNIVERSAL DRIVES.

L22 - UNIVERSAL DRIVES

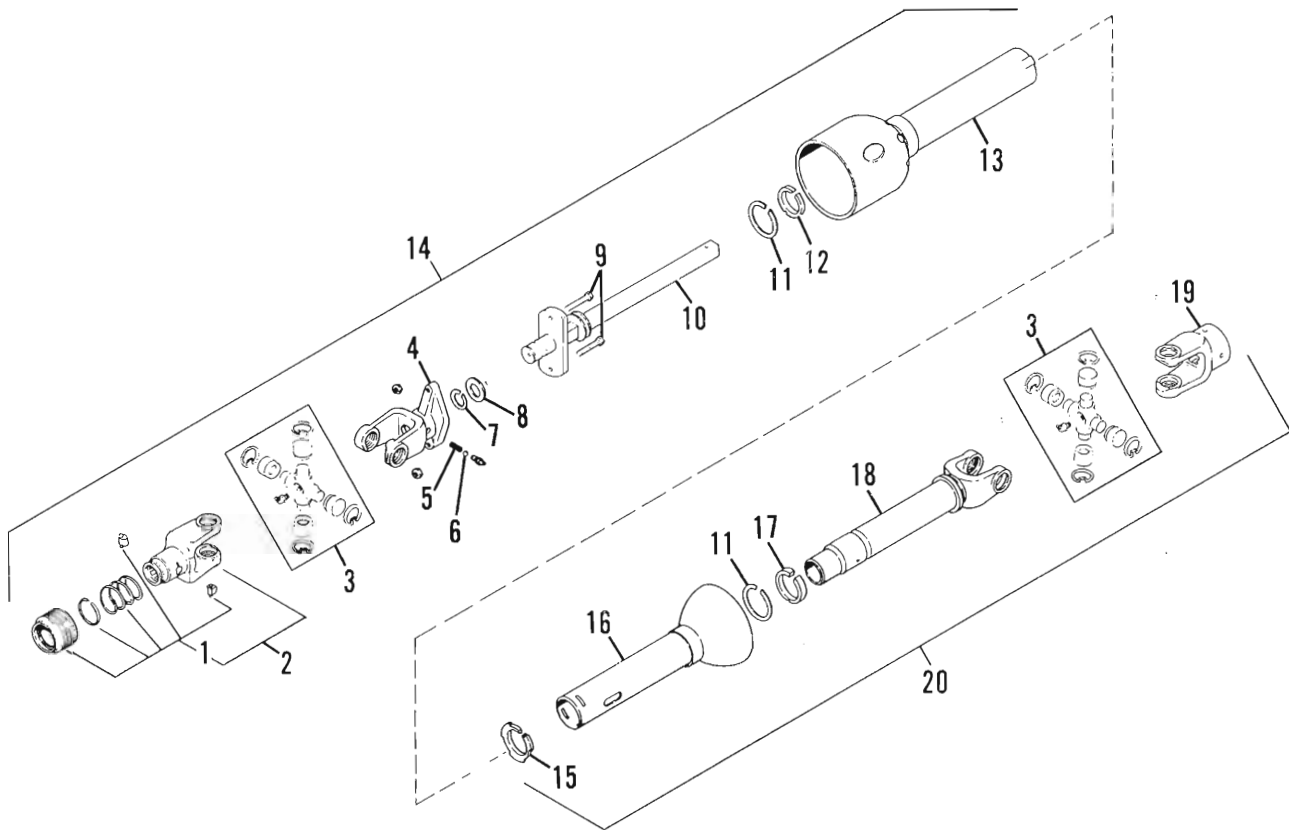

REF NO	PART NUMBER	PART DESCRIPTION...ETC..	QTY REQ	REF NO	PART NUMBER	PART DESCRIPTION...ETC..	QTY REQ
	081677	SHAFT/PTO W/SAFETY YOKE.. ASSEMBLY	1	12	510023	BEARING, NYLON.....	1
		CONSISTS OF:		13	089972	SHIELD, TRACTOR HALF.....	1
01	067537	SLIDE LOCK REPAIR KIT....	1	14	089976	PTO, TRACTOR HALF.....	1
02	065247	YOKE/SLIDE ASSEMBLED.....	1			W/SHIELD	
03	045327	KIT/CROSS.....	2	15	510215	NYLON CENTRALIZER.....	1
	570009	FITTING/GREASE.....	2	16	089975	SHIELD, MACHINE HALF.....	1
04	054117	YOKE/SHEAR.....	1	17	510202	BEARING, NYLON.....	1
	570002	FITTING/GREASE.....	1	18	089965	YOKE & TUBE ASSY.....	1
05	045884	SPRING/COMPRESSION.....	1	19	081507	YOKE.....	1
06	060120	BALL/5/16 STEEL.....	1	20	089977	PTO, MACHINE HALF.....	1
07	045882	RING/RETAINING.....	1			W/SHIELD	
08	045883	WASHER.....	1		650906	SQHSS 3/8X1 (JN).....	2
09	062372a	SHEAR BOLT/5/16X2 GR5.... (2) 5/16LN	2				
10	089971	PTO SHAFT W/SHEAR FLANGE..	1				
11	510100	RETAINER, BEARING.....	4				
						a) FOR REPLACEMENT SHEAR BOLTS, ORDER 900014 CONTAINING 8 BOLTS & LN.	

L22 - UNIVERSAL DRIVES

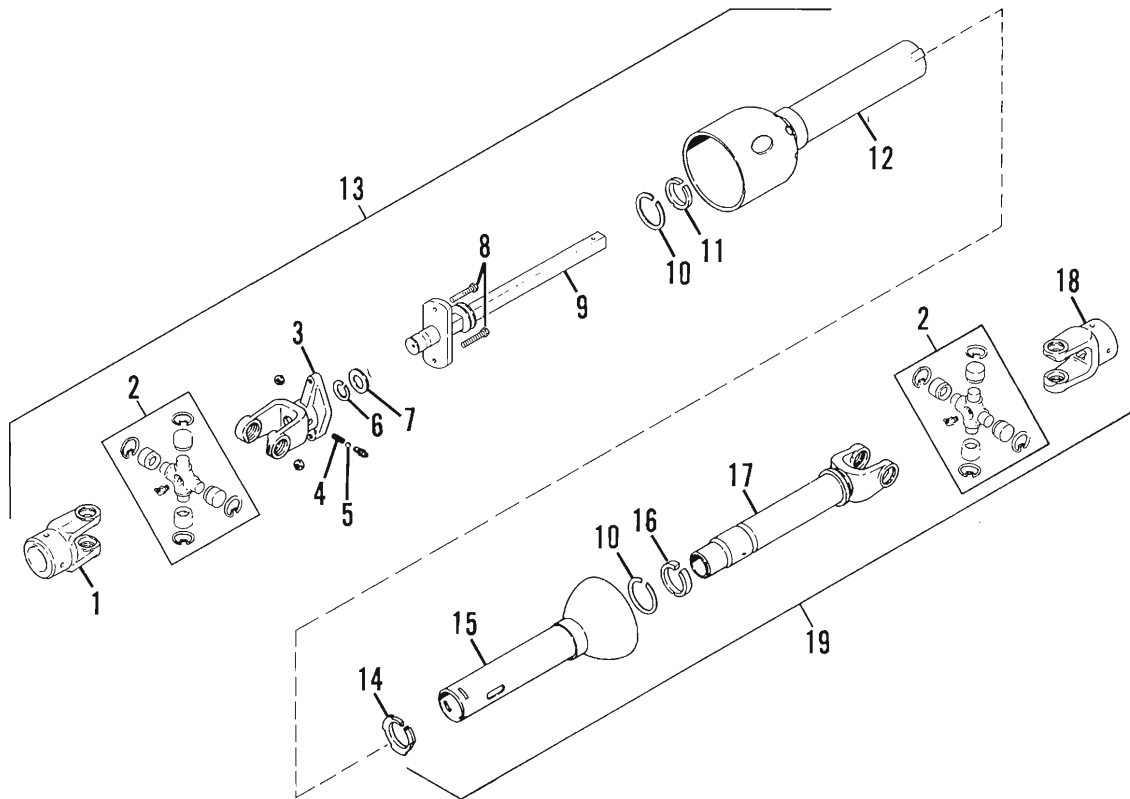

REF NO	PART NUMBER	PART DESCRIPTION...ETC..	QTY REQ	REF NO	PART NUMBER	PART DESCRIPTION...ETC..	QTY REQ
	606100	PTO SHAFT.....	1	11	510023	BEARING, NYLON.....	1
		CONSISTS OF:		12	089972	SHIELD, SHAFT HALF.....	1
01	089971	YOKE.....	1	13	089978	PTO, SHAFT HALF W/SHIELD.	1
02	045327	KIT/CROSS.....	2	14	510217	NYLON CENTRALIZER.....	1
	570009	FITTING/GREASE.....	2	15	089975	SHIELD, TUBE HALF.....	1
03	054117	YOKE/SHEAR.....	1	16	510202	BEARING, NYLON.....	1
	570002	FITTING/GREASE.....	1	17	089973	YOKE & TUBE ASSY.....	1
04	045884	SPRING/COMPRESSION.....	1	18	081507	YOKE.....	1
05	060120	BALL/5/16 STEEL.....	1	19	089979	PTO, TUBE HALF W/SHIELD..	1
06	045882	RING/RETAINING.....	1		650906	SQHSS 3/8X1 (JN).....	2
07	045883	WASHER.....	1				
08	062372a	SHEAR BOLT/5/16X2 GR5....	2				
		(2) 5/16LN					
09	089971	PTO SHAFT W/SHEAR FLANGE.	1				
10	510100	RETAINER, BEARING.....	4				

a) FOR REPLACEMENT SHEAR BOLTS, ORDER 900014 CONTAINING 8 BOLTS & LN.

L22 - UNIVERSAL DRIVES

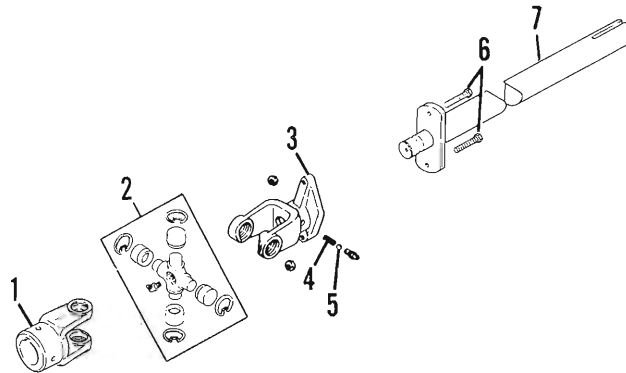

REF NO	PART NUMBER	PART DESCRIPTION...ETC..	QTY REQ	REF NO	PART NUMBER	PART DESCRIPTION...ETC..	QTY REQ
	606084	SHAFT.....	1	05	060120	BALL/5/16 STEEL.....	1
		CONSISTS OF:		06	061699a	SHEAR BOLT/5/16X2 GR2....	2
01	081507	YOKE.....	1			(2) 5/16LN	
02	045327	KIT/CROSS.....	2	07	089969	SHAFT W/SHEAR FLANGE.....	1
	570009	FITTING/GREASE.....	2				
03	089967	YOKE/SHEAR.....	1				
	570004	FITTING/GREASE.....	1				
04	045884	SPRING/COMPRESSION.....	1				

a) FOR REPLACEMENT SHEAR BOLTS, ORDER 900087 CONTAINING 8 BOLTS & LN.

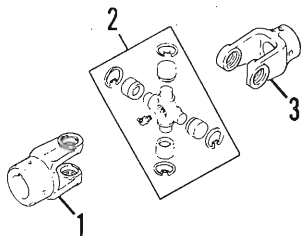

REF NO	PART NUMBER	PART DESCRIPTION...ETC..	QTY REQ
	606101	35 SERIES U-JOINT.....	1
		CONSISTS OF:	
01	084245	YOKE 1-3/4.....	1
02	045327	KIT/CROSS.....	1
	570009	FITTING/GREASE.....	1
03	089968	YOKE 1-3/8.....	1

L22 - RIGHT ANGLE GEARBOX

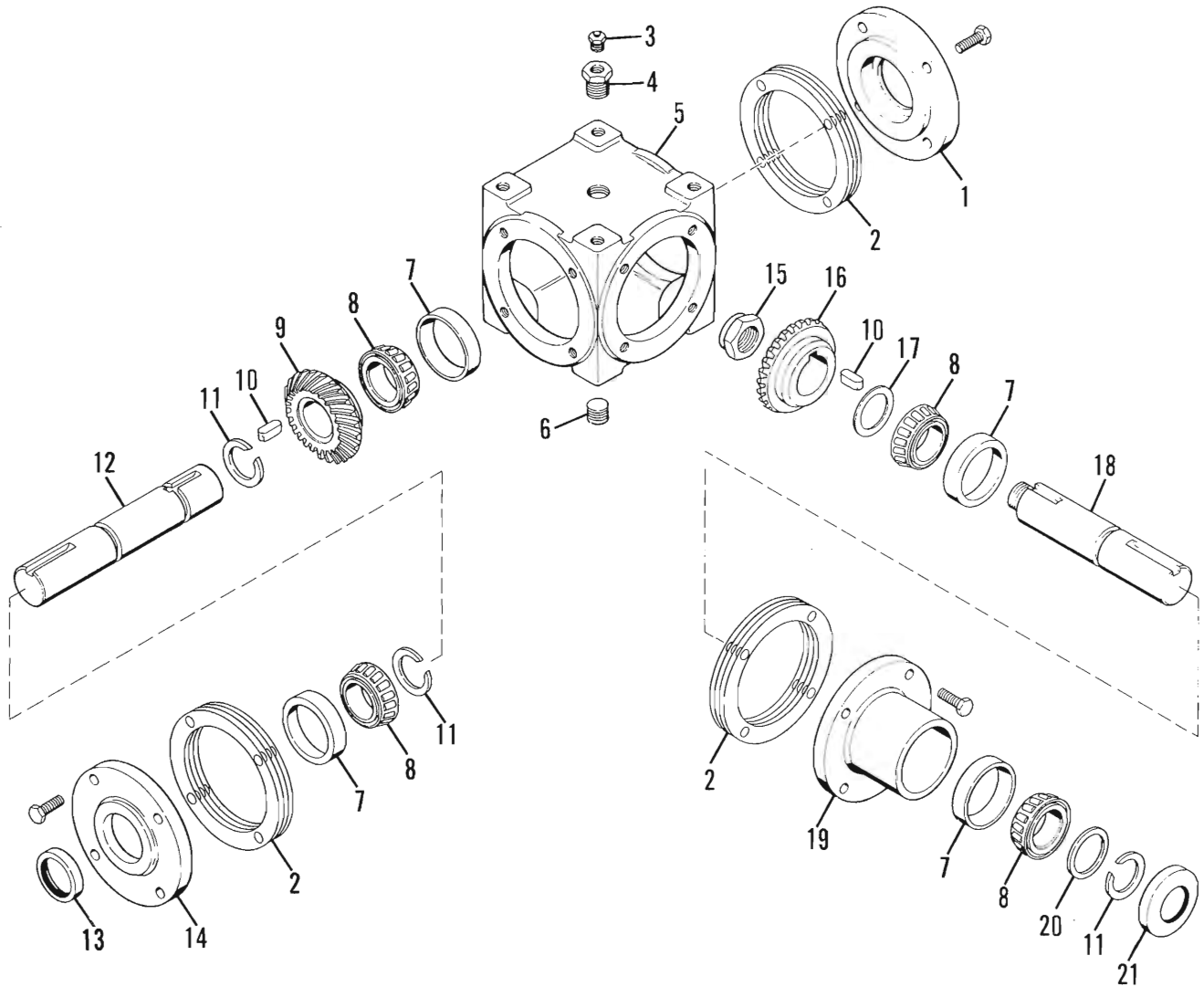

REF NO	PART NUMBER	PART DESCRIPTION...ETC..	QTY REQ	REF NO	PART NUMBER	PART DESCRIPTION...ETC..	QTY REQ
	606102	GEARBOX-ASSEMBLED.....	1	11	089817	SNAP RING.....	3
		CONSISTS OF:		12	089785	OUTPUT SHAFT (CROSS).....	1
01	089789	CLOSED END CAP.....	1	13	089813	SEAL (CROSS SHAFT).....	1
	650059	CS 3/8-16X1.....	4	14	089790	OPEN END CAP.....	1
02	089780	GASKET.....	AR		650059	CS 3/8-16X1.....	4
03	089818	PRESSURE RELIEF VENT.....	1	15	089775	PINION NUT.....	1
04	089819	PIPE THREAD BUSHING.....	1	16	089784	GEAR, SPIRAL BEVEL, L.H..	1
05	089783	CASE.....	1	17	064478	SHIM 0.005.....	1
06	660004	1/2 PIPE PLUG.....	2	18	089786	INPUT SHAFT (PINION).....	1
07	089815	BEARING CUP.....	4	19	089788	PINION HOUSING.....	1
08	089814	BEARING CONE.....	4	20	089792	SPACER WASHER.....	2
09	089787	GEAR, SPIRAL BEVEL, R.H..	1	21	089812	SEAL (PINION SHAFT).....	1
10	089816	KEY 5/16X5/16X15/16.....	2				

L22 - "T" STYLE GEARBOX

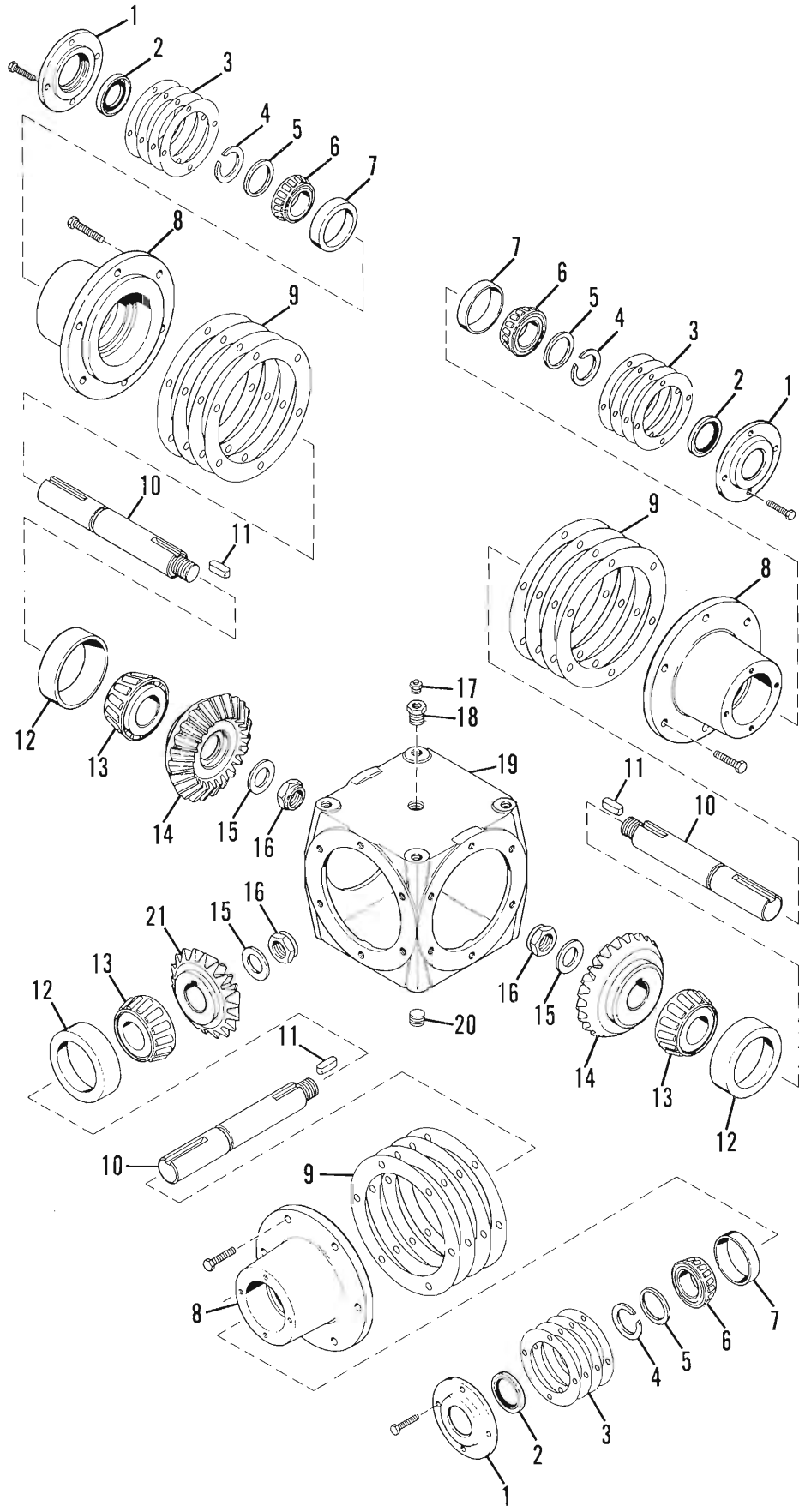

L22 - "T" STYLE GEARBOX

REF NO	PART NUMBER	PART DESCRIPTION...ETC..	QTY REQ	REF NO	PART NUMBER	PART DESCRIPTION...ETC..	QTY REQ
	606098	GEARBOX-ASSEMBLED.....	1	10	089774	INPUT SHAFT (PINION).....	3
		CONSISTS OF:		11	C 14036	KEY 3/8SQ.X1-1/2.....	3
01	089779	SEAL HOLDER.....	3	12	089823	BEARING CUP.....	3
	650004	CS 1/4-20X3/4.....	12	13	089824	BEARING CONE.....	3
02	089825	SEAL.....	3	14	089776	GEAR.....	2
03	089778	GASKET.....	AR	15	089791	PINION WASHER.....	3
04	089820	SNAP RING.....	3	16	089775	PINION NUT.....	3
05	089781	SPACER WASHER.....	3	17	089818	PRESSURE RELIEF VENT.....	1
06	089822	BEARING CONE.....	3	18	089819	PIPE THREAD BUSHING.....	1
07	089821	BEARING CUP.....	3	19	089772	CASE.....	1
08	089777	PINION HOUSING.....	3	20	660004	1/2 PIPE PLUG.....	2
	650059	CS 3/8-16X1.....	18	21	089773	PINION GEAR.....	1
09	089782	GASKET.....	AR				

L22 - NUMERICAL INDEX



PART NO.	PAGE NO.	REF. NO.	PART NO.	PAGE NO.	REF. NO.	PART NO.	PAGE NO.	REF. NO.	PART NO.	PAGE NO.	REF. NO.	
9H	300	27	16	081623	31	03	089785	35	12	510100	32	11
B	11221	31	04	081630	31	12	089786	35	18	510100	33	10
C	14036	37	11	081634	31	17	089787	35	09	510202	32	17
045327	32	03	081635	31	22	089788	35	19	510202	33	16	
045327	33	02	081639	27	03	089789	35	01	510215	32	15	
045327	34	02	081643	27	12	089790	35	14	510217	33	14	
045327	34	02	081648	27	11	089791	37	15	580116	27	08	
045882	32	07	081658	27	04	089792	35	20	606084	29	07	
045882	33	06	081662	27	02	089812	35	21	606084	34		
045883	32	08	081667	27	01	089813	35	13	606086	27	07	
045883	33	07	081677	29	01	089814	35	08	606087	29	23	
045884	32	05	081677	32		089815	35	07	606088	31	09	
045884	33	04	081680	31	06	089816	35	10	606089	31	02	
045884	34	04	081686	31	23	089817	35	11	606090	29	09	
054117	32	04	081691	29	21	089818	35	03	606091	29	29	
054117	33	03	081693	29	10	089818	37	17	606091	31	08	
056230	29	03	081697	29	26	089819	35	04	606093	29	18	
056230	31	14	081698	29	13	089819	37	18	606094	31	07	
059566	29	08	081699	29	12	089820	37	04	606095	29	22	
060120	32	06	081700	29	11	089821	37	07	606096	31	21	
060120	33	05	081701	29	20	089822	37	06	606097	29	19	
060120	34	05	081706	31	20	089823	37	12	606098	29	04	
060471	27	06	081707	31	05	089824	37	13	606098	37		
060471	29	16	082266	29	15	089825	37	02	606100	29	05	
060629	27	05	083290	27	08	089965	32	18	606100	33		
061699	34	06	084245	34	01	089967	34	03	606101	31	15	
061699	29	06	084377	31	01	089968	34	03	606101	34		
062372	32	09	084540	31	13	089969	34	07	606102	31	13	
062372	33	08	089772	37	19	089971	32	10	606102	35		
062372	29	02	089773	37	21	089971	33	01	606131	29	17	
064478	35	17	089774	37	10	089971	33	09	606132	31	18	
064861	29	14	089775	35	15	089972	32	13	606134	31	11	
065247	32	02	089775	37	16	089972	33	12	606135	31	16	
067537	32	01	089776	37	14	089973	33	17	606136	29	30	
067880	27	09	089777	37	08	089975	32	16	606137	29	31	
070880	27	13	089778	37	03	089975	33	15	606140	29	28	
080914	27	14	089779	37	01	089976	32	14	606223	27	10	
081507	32	19	089780	35	02	089977	32	20	606234	27	15	
081507	33	18	089781	37	05	089978	33	13	660004	35	06	
081507	34	01	089782	37	09	089979	33	19	660004	37	20	
081576	29	24	089783	35	05	510023	32	12	660025	29	25	
081578	29	27	089784	35	16	510023	33	11	660043	31	19	
081592	31	10										

INDEX

	Page		Page
A			
Adjustments	17	Tractor Mounting	15
Scoop Auger Drive Chain	17	PTO Connection	15
Loading Auger Drive Chain	17	Hydraulic Connections	16
C			
Checklists	5-7	Operating Loader	16
Controls & Safety Equipment	13-14	Unplugging	16
Guards & Shields	13	Overload Protection	16
Loading Auger Drive Shaft	13	PTO (Power Take Off)	16
Loading Auger Height Control	13	Scoop Auger Drive	16
Loading Auger Storage Stand	13-14	Loading Auger Drive	16
Scoop Height Control	14	Optional Features & Accessories	19
Telescoping PTO Drives	14	Shear Bolts	19
D			
Decal Locations	24-25	P	
General Information	24	Preparing for Field Operation	19
New Decal Application	24-25	S	
I			
Introduction	2	SAFETY	8-12
L			
Lubrication	18	Service	19
General Information	18	Set Screws	19
Gearboxes	18	Service Parts & Numerical Index	26-38
Oiling	18	Lift System & Parking Stand	27
Greasing	18	Scoop Assembly	28-29
M			
MANDATORY SAFETY		Loading Auger Assembly	30-31
SHUTDOWN PROCEDURE	8	Universal Drives	32-34
O			
Operation	15-16	Gearboxes	35-37
General Information	15	Numerical Index	38
Emergency Shut-down	15	Set-up & Assembly	20-23
		Specifications	3
		Standard Hardware Torque Data ..	Inside Back Cover
		Storage	19
		T	
		Table of Contents	1
		W	
		Warranty	Inside Front Cover

NOTES

TORQUE SPECIFICATIONS FOR STANDARD MACHINE HARDWARE

SIZE	SAE GRADE #2 		SAE GRADE #5 		SAE GRADE #8 	
	DRY	LUB.	DRY	LUB.	DRY	LUB.
8 - 32	19 in. Lbs.	14 In. Lbs.	30 In. Lbs.	22 In. Lbs.	41 In. Lbs.	31 In. Lbs.
8 - 36	20 "	15 "	31 "	23 "	43 "	32 "
10 - 24	27 "	21 "	43 "	32 "	60 "	45 "
10 - 32	31 "	23 "	49 "	36 "	68 "	51 "
1/4 - 20	66 "	50 "	9 Ft. Lbs.	75 "	12 Ft. Lbs.	9 Ft. Lbs.
1/4 - 28	76 "	56 "	10 "	86 "	14 "	10 "
5/16 - 18	11 Ft. Lbs.	9 Ft. Lbs.	17 "	13 Ft. Lbs.	25 "	18 "
5/16 - 24	12 "	9 "	19 "	14 "	25 "	20 "
3/8 - 16	20 "	15 "	30 "	23 "	45 "	35 "
3/8 - 24	23 "	17 "	35 "	25 "	50 "	35 "
7/16 - 14	32 "	24 "	50 "	35 "	70 "	55 "
7/16 - 20	36 "	27 "	55 "	40 "	80 "	60 "
1/2 - 13	50 "	35 "	75 "	55 "	110 "	80 "
1/2 - 20	55 "	40 "	90 "	65 "	120 "	90 "
9/16 - 12	70 "	55 "	110 "	80 "	150 "	110 "
9/16 - 18	80 "	60 "	120 "	90 "	170 "	130 "
5/8 - 11	100 "	75 "	150 "	110 "	220 "	170 "
5/8 - 18	110 "	85 "	180 "	130 "	240 "	180 "
3/4 - 10	175 "	130 "	260 "	200 "	380 "	280 "
3/4 - 16	200 "	150 "	300 "	220 "	420 "	320 "
7/8 - 9	170 "	125 "	430 "	320 "	600 "	460 "
7/8 - 14	180 "	140 "	470 "	360 "	660 "	500 "
1 - 8	250 "	190 "	640 "	480 "	900 "	680 "
1 - 12	270 "	210 "	710 "	530 "	1000 "	740 "

Multiply in Lbs. by (0.113) or Ft. Lbs. by (1.355) for metric Nm

NOTE: These torque values are to be used for all hardware excluding: locknuts, self-tapping screws, thread forming screws, and sheet metal screws. Unless otherwise noted, all torque values must meet this specification.

GEHL®

FARM EQUIPMENT

GEHL COMPANY WEST BEND, WISCONSIN 53095 U.S.A.